

# **INSTRUCTION MANUAL FOR VACUUM DRYING OVENS**

**Models: DP23  
DP33  
DP43  
DP63**

**Version 3**

**Yamato Scientific America Inc.**

**Santa Clara, CA**

**1-800-2-YAMATO (1-800-292-6286)**

Congratulations on your selection of Yamato Scientific's DP Vacuum Drying Oven Series!  
Please read these operating instructions, user notes and the warranty card thoroughly before the initial operation of your VACUUM drying oven. This will ensure proper operating procedures and extended life for the unit. Please keep the operating instructions together with the warranty card for easy access whenever you need them.

**Attention: Read the warnings in the operating instructions carefully to familiarize yourself with the initial operation of your Vacuum drying oven.**

Depending on the extent and nature of danger, the warnings given in these operating instructions are classified into the following two categories by symbol.

To protect operators from accident --  
Negligence of this warning may result in a serious accident.

To protect the VACUUM Drying Oven from damage --  
Negligence of this warning may result in damage to the Vacuum Drying Oven.  
This warning also gives you tips on performance that are useful in its operation and maintenance or indicates the common mistakes that operators often make.

# TABLE OF CONTENTS

<b>EXPLANATION OF PICTURE DISPLAY</b> .....	<b>1</b>
<b>CAUTIONS IN USING WITH SAFETY</b> .....	<b>2</b>
<b>NOTES TO USERS</b> .....	<b>4</b>
<b>DESCRIPTION AND FUNCTION OF EACH PART</b> .....	<b>4</b>
<i>Main unit (Model DP23/33)</i> .....	<i>4</i>
<i>Main unit (Model DP43/63)</i> .....	<i>5</i>
<i>Control Panel</i> .....	<i>6</i>
<b>REQUIREMENTS FOR INSTALLATION</b> .....	<b>8</b>
<b>PRECAUTIONS IN HANDLING</b> .....	<b>14</b>
<b>OPERATING PROCEDURE</b> .....	<b>18</b>
<b>FIXED TEMPERATURE OPERATION INSTRUCTIONS</b> .....	<b>19</b>
<b>AUTO START OPERATION INSTRUCTIONS</b> .....	<b>20</b>
<b>AUTO STOP OPERATION METHOD</b> .....	<b>21</b>
<b>PROGRAMMED OPERATION METHOD</b> .....	<b>23</b>
<b>SWITCHING FROM ONE OPERATION TO ANOTHER</b> .....	<b>24</b>
<b>METHOD OF USING DISPLAY KEY</b> .....	<b>25</b>
<b>USAGE OF MODE</b> .....	<b>26</b>
<b>CONTENT OF FUNCTION MENU</b> .....	<b>26</b>
<b>CALIBRATION OFFSET FUNCTION</b> .....	<b>27</b>
<i>Outline of Function</i> .....	<i>27</i>
<i>Setting The Calibration Offset Function</i> .....	<i>28</i>
<b>SAFETY DEVICES AND ERROR CODES</b> .....	<b>29</b>
<b>PURPOSES AND OPERATIONS OF SAFETY DEVICE AND COUNTER-MEASURES</b> .....	<b>29</b>
<b>INDEPENDENT OVERHEAT PREVENTION</b> .....	<b>30</b>
<b>MAINTENANCE AND INSPECTION</b> .....	<b>31</b>
<b>MAINTENANCE PROCEDURE</b> .....	<b>32</b>
<b>LONG STORAGE AND DISPOSAL</b> .....	<b>32</b>
<b>AFTER SERVICE AND WARRANTY</b> .....	<b>33</b>
<b>IF A SERVICE CALL IS REQUIRED:</b> .....	<b>33</b>
<b>TROUBLESHOOTING</b> .....	<b>34</b>
<b>SPECIFICATIONS</b> .....	<b>35</b>
<b>WIRING DIAGRAM</b> .....	<b>36</b>
(DP23/33) - AC 115V.....	36
(DP43/63) - AC 220V.....	37
<b>HEATER DETAILS</b> .....	<b>38</b>
<b>REPLACEMENT PARTS TABLE</b> .....	<b>39</b>
DP23 .....	39
DP33 .....	39
DP43 .....	40
DP63 .....	40
<b>REFERENCE</b> .....	<b>41</b>
<b>HAZARDOUS MATERIAL</b> .....	<b>41</b>
<b>EXPLANATION OF CHARACTER ON THE DISPLAY</b> .....	<b>42</b>
<b>BEHAVIOR AFTER POWER RESTORATION</b> .....	<b>43</b>
<b>FLOWCHART OF OPERATIONAL PROCEDURES</b> .....	<b>44</b>
<b>RUN "MENU"</b> .....	<b>44</b>
<b>PROGRAM "MODE"</b> .....	<b>45</b>
<b>FLOWCHART FOR PROGRAMMING</b> .....	<b>46</b>
<b>REFERENCE DATA</b> .....	<b>47</b>

## Explanation of picture display

### MEANING OF ILLUSTRATED SYMBOLS

#### Illustrated Symbols

Various symbols are used in this safety manual in order to use the unit without danger of injury and damage of the unit. A list of problems caused by ignoring the warnings and improper handling is divided as shown below.

Be sure that you understand the warnings and cautions in this manual before operating the unit.



#### Warning

If the warning is ignored, there is the danger of a problem that may cause a serious accident or even fatality.



#### Caution

If the caution is ignored, there is the danger of a problem that may cause injury/damage to property or the unit itself.

### Meaning of Symbols



This symbol indicates items that urge the warning (including the caution).

A detailed warning message is shown adjacent to the symbol.



This symbol indicates items that are strictly prohibited.

A detailed message is shown adjacent to the symbol with specific actions not to perform.



This symbol indicates items that should be always performed.

A detailed message with instructions is shown adjacent to the symbol.

## Cautions in using with safety

### WARNING

**⊘ Do not use the unit in an area where there is flammable or explosive gas.**

- Never use the unit in an area where there is flammable or explosive gas. The unit is not explosion-proof. An arc may be generated when the power switch is turned on or off, and fire/explosion may result.

**⚠ Always ground the unit.**

- Always ground the unit on the power equipment side in order to avoid electrical shock due to a power surge.

**⚠ If a problem occurs, you should:**

- If smoke or strange odor should come out of the unit for some reason, **turn off** the power key right away, then **turn off** the circuit breaker and the main power. Immediately contact a service technician for inspection. If this procedure is not followed, fire or electrical shock may result.

Never perform repair work yourself, since it is dangerous and not recommended.

**⊘ Do not use the power cord if it is bundled or tangled.**

- Do not use the power cord if it is bundled or tangled. If it is used in this manner, it can overheat and fire may be caused.

**⊘ Do not process, bend, wring, or stretch the power cord forcibly.**

- Do not process, bend, wring, or stretch the power cord forcibly. Fire or electrical shock may result.

**⊘ Do not put the power cord under the desk, chair, etc.,**

- Do not put the power cord under the desk, chair, etc., or through an object. Fire or electrical shock may be caused.

**⊘ Do not run the power cord next to heating equipment such as a heater.**

- Do not run the power cord next to heating equipment such as a heater. The cover of the cord may melt and fire or electrical shock may result.

## WARNING

### ⊘ Substances that can not be used.

- Never use explosive substances, flammable substances and substances that include explosive or flammable ingredients in the unit. Explosion or fire may occur.

### ⊘ Do not disassemble or modify the unit.

- Do not reconfigure the unit. Fire or electrical shock may be caused.

### ⊘ Do not touch the door or window during or immediately after operation.

- Do not touch the door or the window during or immediately after operation. Severe burning injury may be caused due to the high temperature.

## CAUTION

### ⚠ During a thunder storm . . .

- During a thunder storm, **turn off** the power key immediately, then **turn off** the circuit breaker and the main power. If this procedure is not followed, fire or electrical shock may be caused.

### ⚠ Periodic check of the safety component.(Only DP43/63)

- The independent temperature over-rise prevention device is important safety component. Be sure to inspect it periodically. (See Chapter on Maintenance & Inspection.)

# Notes to Users

## DESCRIPTION AND FUNCTION OF EACH PART

### Main unit (Model DP23/33)

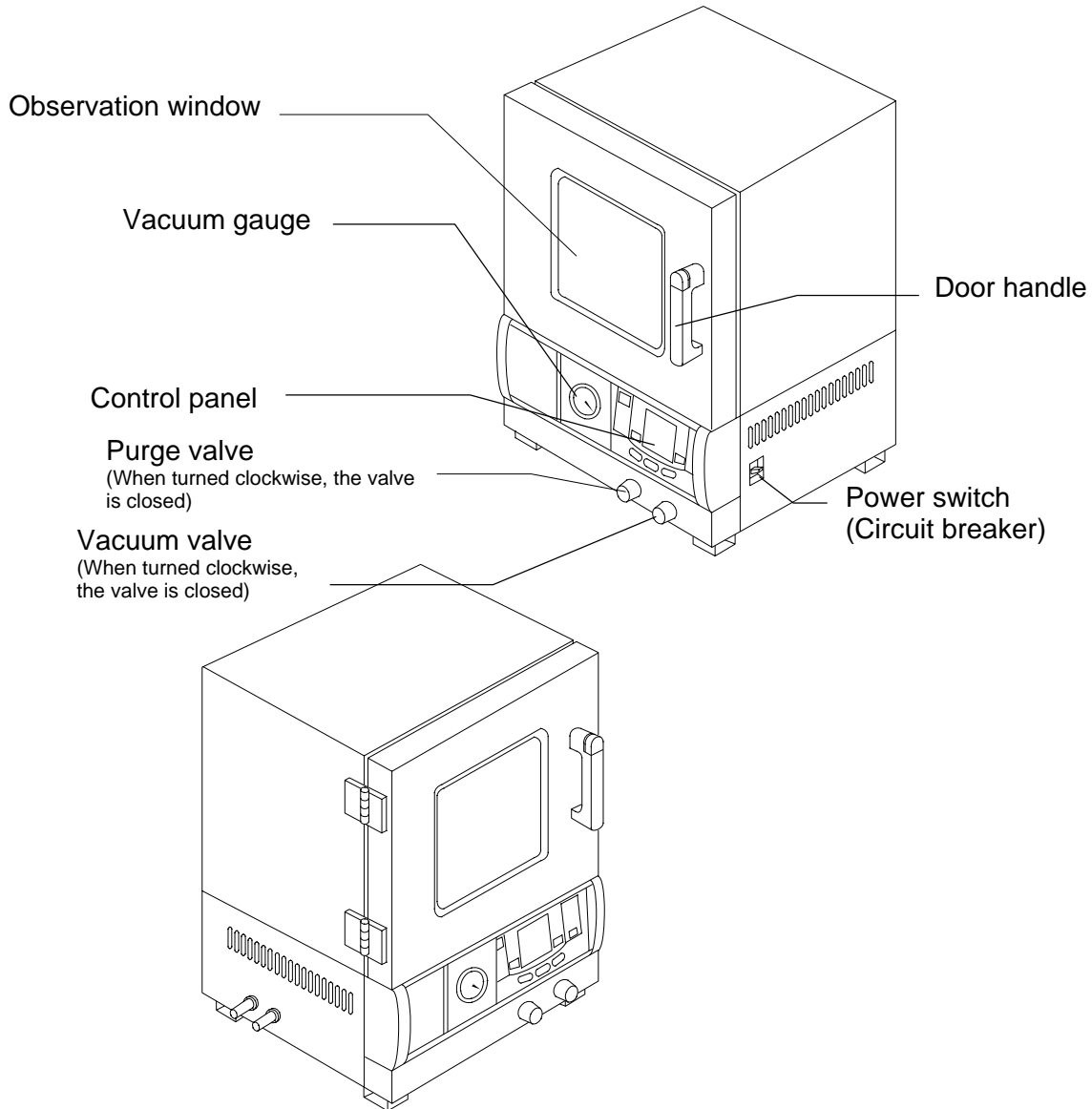

**Main unit (Model DP43/63)**

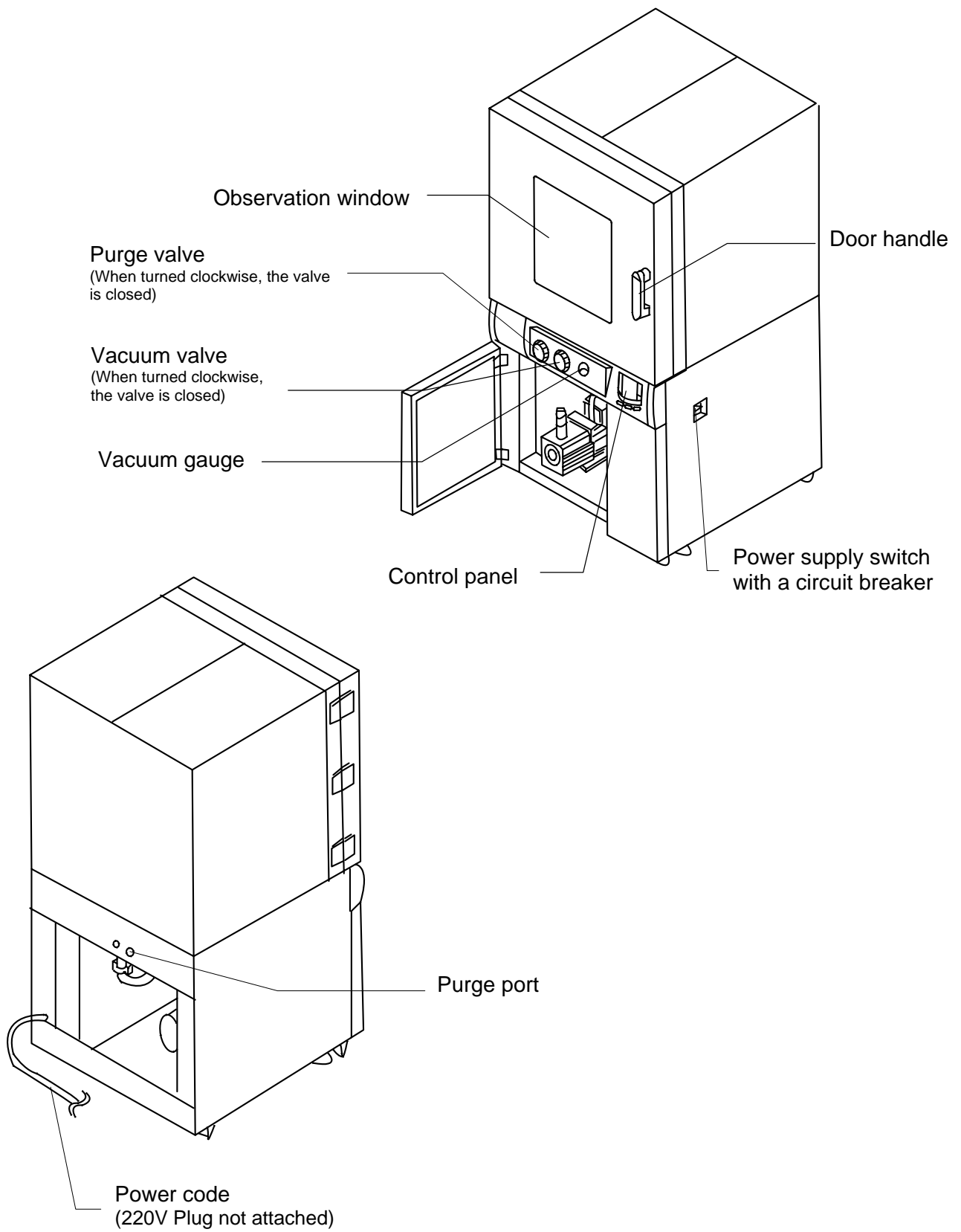



## Control Panel

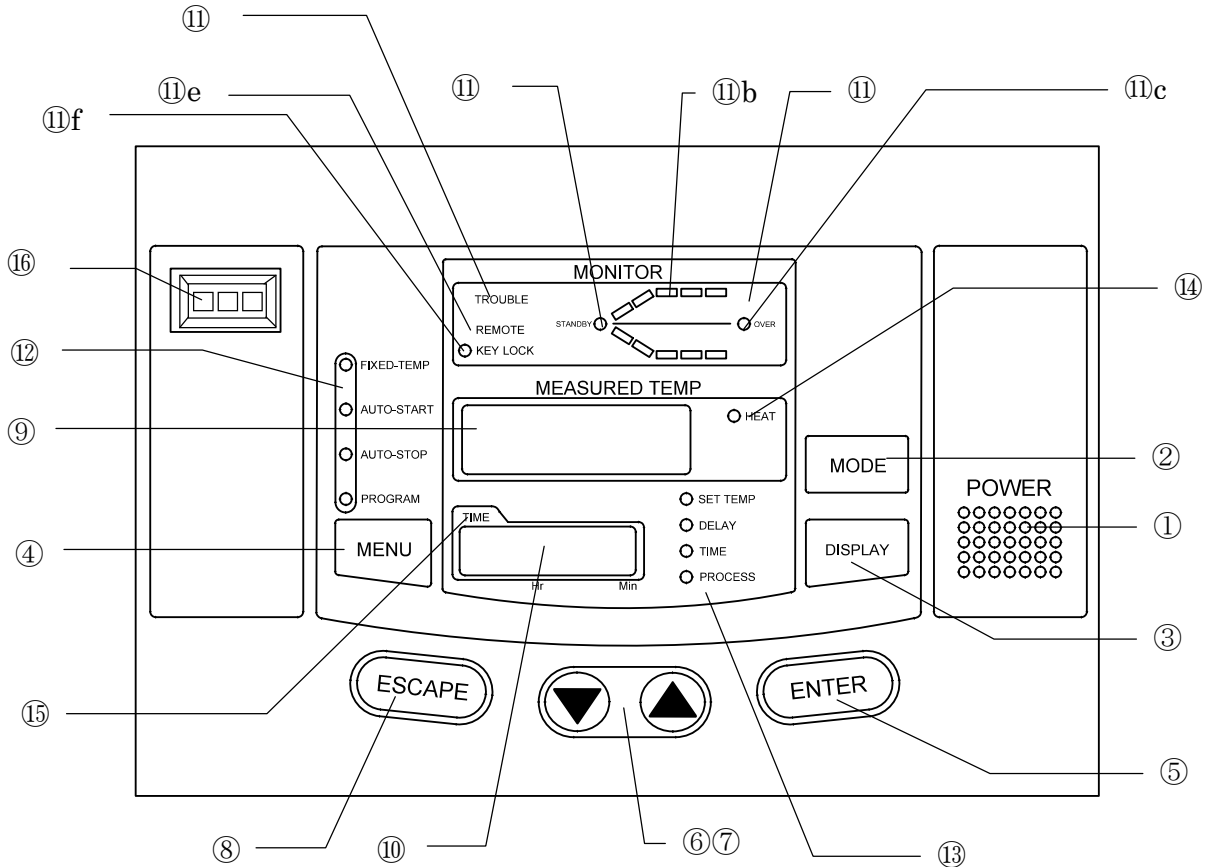

(1) <b>POWER</b> key:	Key to change over the controller from the standby mode to the operation mode or from the operation mode to the standby mode.
(2) <b>MODE</b> key:	Key to select a function from program input, edit, delete modes, hour/time setting, change-over mode, and other functions.
(3) <b>DISPLAY</b> key:	Key to change-over the display content of the sub display (10). Display content is changed over to set temperature, remaining time, hour, execution segment No.
(4) <b>MENU</b> key:	Key to select the operation mode. Each mode of fixed temperature, auto-start, auto-stop and program operation can be selected.
(5) <b>ENTER</b> key:	Key to determine the input value of set value (temperature, time, hour, etc.), selection mode, execution segment No. etc.
(6)/(7) <b>▼▲(UP/DOWN)</b> key:	Key to change set value (temperature, time, hour, etc.) and to choose a selection from various parameters on the function menu.
(8) <b>ESCAPE</b> key:	Key to cancel the latest entry and recover the status that was valid prior to the making the latest selection.
(9) Main Display:	It displays temperature measurements, set values (temperature, time, hour, etc.), program information, error information, etc.
(10) Sub Display:	It displays set temperature, remaining time, current hour and execution segment No. etc.
(11) Operation monitor:	It indicates an operation mode.
a) (11) <b>STANDBY</b> lamp:	It flashes to indicate that the instrument is in the preoperational standby mode.
b) (11) Temperature pattern lamp:	It illuminates to indicate the heat treatment process pattern executed by the controller with flashing light indicating the point currently in execution.
c) (11) <b>OVER</b> lamp:	It flashes to indicate the end of auto-stop or program operation.
d) (11) <b>TROUBLE</b> indicator lamp:	It blinks when an error is detected and displays the corresponding code for that particular problem.

e) (11) <b>REMOTE</b> operation indicator lamp:	It illuminates when the instrument is put into remote operation (optional) and displays the word " <b>REMOTE.</b> "
f) (11) <b>KEY LOCK</b> indicator lamp:	It illuminates to indicate that the operation panel key lock function is in operation.
(12)Operation menu indicator lamp:	It illuminates to indicate the active operation mode in the operation menu.
(13)Sub display menu indicator lamp:	It illuminates to indicate the item (set temperature, remaining time, hour or execution segment) shown in the sub display.
(14) <b>HEAT ON</b> indicator lamp	It illuminates when the heater is on.
(15) <b>TIME</b> indicator lamp:	It illuminates when the operation starting time of the auto-start and the operation completion time of the auto-stop is set in the hour setting mode.
(16)Independent Temperature Overheating Prevention Device:	Setting the instrument to the operational temperature of the independent over rising prevention.

## REQUIREMENTS FOR INSTALLATION

### Do not use the unit in an area where there is flammable or explosive gas.



Never use the unit in an area where there is flammable or explosive gas. The unit is not explosion-proof. An arc may be generated when the power switch is turned ON or OFF, and fire/explosion may result.

~~Explosive gas~~

~~Flammable gas~~

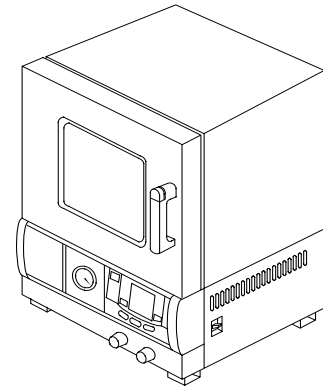
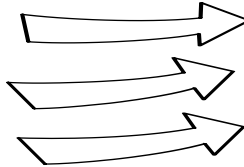

### Always ground the unit.



- Connect the Oven's power plug to a receptacle with grounding connectors.
- Do not forget to ground the Oven, to protect you and the unit from electrical shock in case of power surge. Choose a receptacle with grounding connectors as often as possible.



- Do not connect the grounding wire to a gas pipe, or by means of a lightning rod or telephone line. A fire or electrical shock will occur.

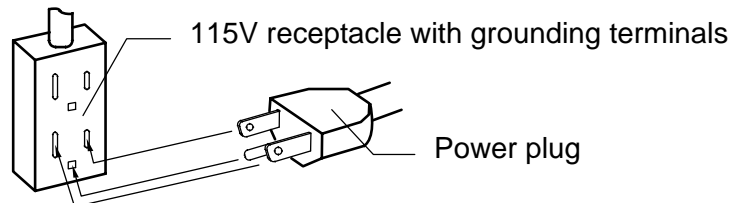

- If only bipolar receptacles are available for the oven, connect an optional grounding adapter to the oven's power plug. Check the polarity of the receptacle before connecting the adapter to the receptacle. Connect the adapter's grounding wire (green) to a grounding terminal to the power supply. Contact our sales representative in your vicinity or our service center for additional information or assistance.

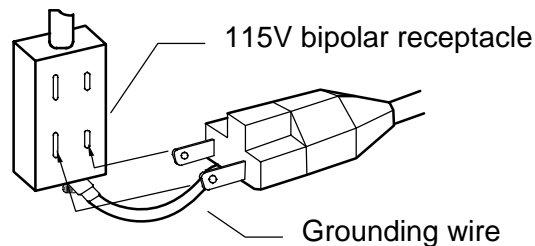

- Connect the proper power supply for any other equipment (vacuum pump, etc.) for this oven. When connecting the other equipment to the same power supply as this oven, be sure that there is enough power for both units.

**NOTE:** Neither of DP43/63 oven has a plug connected because of the 220V specification. Select a plug suitable to this capacity and connect it.

### **Choose a correct power distribution board or receptacle.**



- Choose a correct power distribution board or receptacle that meets the oven's rated electric capacity.

Electric capacity      DP23: 115 VAC, 6A  
                                 DP33: 115 VAC, 9.5A  
                                 DP43: 220 VAC, single phase 10.5A  
                                 DP63: 220 VAC, single phase 14.5A

- Do not connect the oven to an outlet that differs from the above specifications because a fire or electrical shock will occur.

### **Supply connections for Model DP43/63**



- For Model DP43 and DP63 (220V) -- Request the supply connection for the 220V specifications from a licensed electrician.
- Failure to have this operation complete by certified personnel will cause a fire or electrical shock during Oven operation.

### **Install the Oven on a level area.**



- Do not installation the oven on a non level surface. This will cause hazards to the operator and create problems during actual operation.

### Choose a proper place for installation.



- Do not install the oven in a place where:
  - ◆ Flammable gas or corrosive gas is generated.
  - ◆ Ambient temperature exceeds 35°C.
  - ◆ Ambient temperature fluctuates violently.
  - ◆ There is direct sunlight.
  - ◆ There is excessive humidity and dust.
  - ◆ There is constant vibrations.



- Keep the following clearance around the oven.

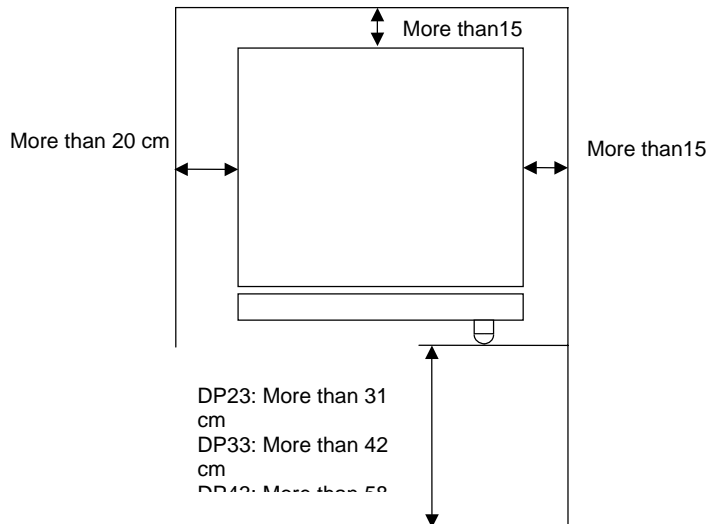

- When installing DP43/63, adjust both right and left adjusters and raise the two front castors from the floor after setting the unit. Then secure the adjusters with nuts.

### After installed, you should:



- It may cause injury to a person if this oven fall down by the earthquake and the impact, etc..
- To prevent, take measures that the unit cannot fall down.

## Connecting a vacuum pump



- Appropriate vacuum pumps for the ovens and the necessary plumbing parts for connecting are listed in the Table below. Referring to this Table, select an appropriate vacuum pump with the necessary plumbing parts. The vacuum pump should have a back current prevention valve attached. Also, the plumbing parts are assembled as optional parts at our facility to comply with your request. (Refer to the Chapter “Options.”)
- Be sure to connect the vacuum port of the oven to the suction port of the vacuum pump with the prescribed plumbing parts to prevent air leakage.
- There is a special storage compartment for a vacuum pump in the lower portion of the DP43/63 ovens. When putting a vacuum pump in this storage compartment, install it properly so that the oil gauge of the vacuum pump can be seen easily from the front of the oven.
- If you select the vacuum pump cart (the exclusive option for the DP43/63 ovens), refer to the instruction manual for the vacuum pump cart and release the bottom board from the unit to store the pump cart in the unit. Before arranging a vacuum pump, be sure that it can be stored in the unit.

**NOTE:** The vacuum pump cart is designed to place a rotary pump up to the following size.

DP43/63 : L 520 mm × W 200 mm × H 280mm

Before purchasing the vacuum pump cart, be sure that your vacuum pump fits the cart .

Contact our sales or service representative, for further information.

## Suitable Displacement Of Vacuum Pump For The Vacuum Oven And Necessary Plumbing Parts

Item	Appropriate Displacement of vacuum pump (L/min)	Nipple/Suction Port of Vacuum Pump	Req. Plumbing Parts
Vacuum Oven <b>DP23/33</b> (Vacuum connection port : φ18mm)	50 ~135	φ3/4”(19mm)	Vacuum rubber tube, I.D. 5/8”(15.8mm): 1 pc.
		φ28mm	Vacuum rubber tube, I.D. 5/8”(15.8mm): 1 pc. Vacuum rubber tube, I.D. 1”(25mm): 1 pc. Reducer A or C( φ18mm/φ30mm): 1 pc.
<b>DP-43/63</b> (Vacuum connection port : NW25)	135 ~ 260	NW25 or KF25 flange	Flexible hose: 1pc. Clamp(NW20/35): 2pc. Center Ring (NW25): 2pc.
		φ28mm	Vacuum rubber tube, I.D. 1”(25mm): 1 pc. Rubber tube adapter: 1 pc. Clamp (NW20/25): 1 pc. Center ring (NW25): 1 pc.

**NOTE: When the connecting port of the oven differs in diameter from the suction port of the vacuum pump, be sure to connect them with the appropriate adapter.**

## Pump and Necessary Plumbing Parts

Port for connecting Model DP23/33 ovens to vacuum pump

O.D.  $\phi$ 18 mm

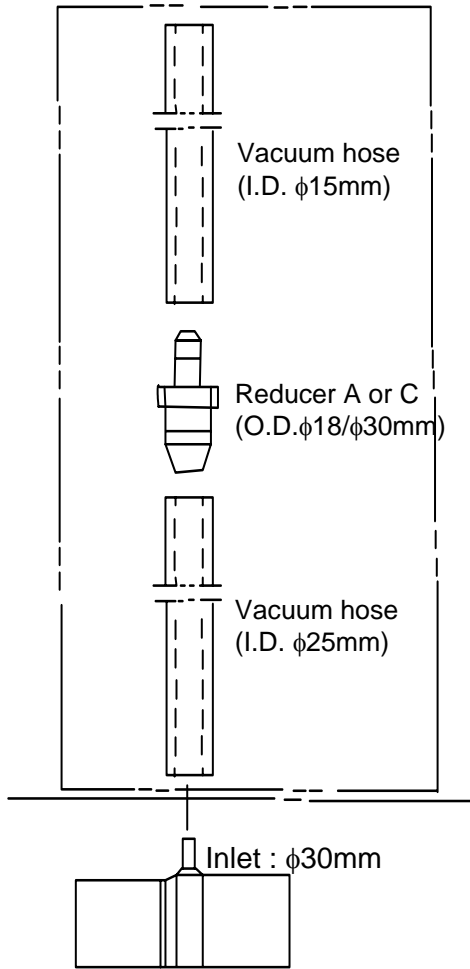

Port for connecting Model DP43/63 ovens to vacuum pump

NW25 flange

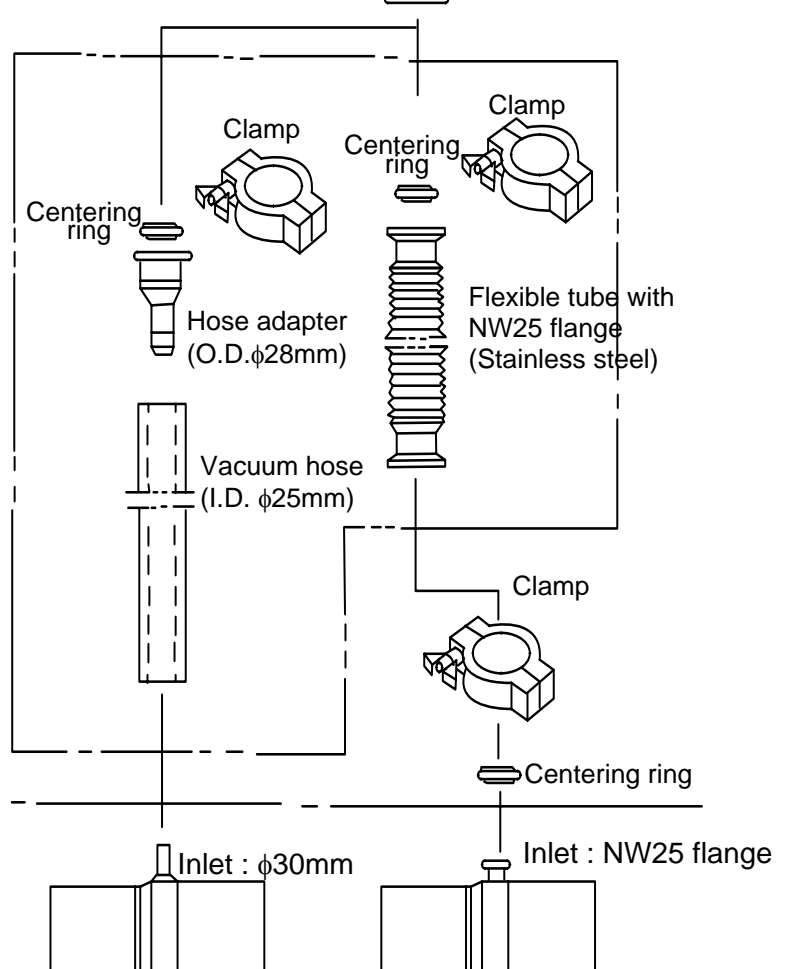

Rotary vane vacuum pump

### Handling of power code.



- Do not use the power cord if it is bundled or tangled. If it is used in this manner, it can overheat and fire may be caused.
- Do not process, bend, wring, or stretch the power cord forcibly. Fire or electrical shock may result.
- Do not put the power cord under the desk, chair, etc., or through an object. Fire or electrical shock may be caused.
- Do not run the power cord next to heating equipment such as a heater. The cover of the cord may melt and fire or electrical shock may result.



- When the power cord is damaged (exposure of the core wires, disconnection, etc.), turn off the power key right immediately, then turn off the circuit breaker and the main power. Contact customer service for a replacement immediately. If this procedure is not followed, fire or electrical shock may be caused.

### Caution in setting shelves



- Do not use any shelves but the attached ones. If it is used in this manner, the oven cannot occasionally regulate temperatures properly.
- Put the attached shelves on the shelf brackets fitted to the chamber when you use the oven.



## Precautions in handling



### Warning

#### Substances that can be used



- Never use explosive substances (shown on page 41) , flammable substances (shown on page 41) and substances that include explosive or flammable ingredients in the unit. Explosion or fire may occur.
- Because copper piping is used for the plumbing, avoid using corrosive substances such as acid, alkali, halogen class, amine class, ester, etc.
- Because silicone rubber is used for the door packing, benzoic acid (used in the rubber manufacturing process) and rubber volatile matter will be generated while the oven is in operation. When using a sample that is affected by these substances, use the optional Viton packing.

**NOTE: The silicone rubber for the standard door packing and fluorocarbon rubber (Viton) for the optional door packing are affected by the substances that are shown in the following Table. Therefore, never dispose of those substances and the samples containing such substances. Inquire about the possibility of using the other substances shown in the Table.**

#### Typical Example of Substance That Affects Door Packing

Material/ Classification	Silicone Rubber	Fluorocarbon Rubber
Carbohydrate	Butane, Isooctane, Benzene, Toluene, Xylene, Styrene, Diphenyl, Pinene, Kerosene	Propane
Halogen, Halogen Carbohydrate	Methyl Chloride, Methylene Chloride, Chloroform, Carbon tetrachloride, Trichlorethylene, Phlorobenzene, Monochlorobenzene, Chlorotoluene, Chloronaphthalene, R-11, R-12, R-21, R-22, R-113, R-114, Bromine	R-21, R-22
Ketone, Aldehyde	Methyl Ethyl Ketone, Diisopropyl, Ketone, Cyclohexanone, Acetophenone	Acetone, Methyl Ethyle Ketone, Methyl Isobutyl Ketone, Diisopropyl Ketone, Cyclohexanone, Acetophenone
Ester	Methyl Acetate, Ethyl Acetate, Propyl Acetate, Butyl Acetate, Amyl Acetate, Ethyl Acetoacetate, Butyl Acrylate, Methyl Methacrylate	Methyl Acetate, Ethyl Acetate, Propyl Acetate, Isopropyl Acetate, Butyl Acetate, Amyl Acetate, Ethyl Acetoacetate, Ethyl Acrylate, Butyl Acrylate, Methyl Methacrylate
Ether	Diethyl Ether, Dibenzyl Ether, Ethylene Oxide, Dioxan, Epichlorohydrin, Tetrahydrofuran	Diethyl Ether, Isopropyl Ether, Dibutyl Ether, Dibenzyl Ether, Ethylene Oxide, Dioxan, Epichlorohydrin, Furfural, Tetrahydrofuran
Alcohol	Amyl Alcohol	
Polyhydric Alcohol Derivative		Ethylene Glycol Monoethyl Ether Acetate, Butyl Cellosolve, Triacetin
Fatty acid, Phenol	Acetic anhydride, Oleic acid, Palmitic acid phenol	Formic acid, Acetic anhydride, Hydroquinone
Nitrogen compound	Nitromethane, Nitroethane, Nitropropane	Nitromethane, Nitroethane, Nitropropane, Ethylenediamine, Dimethylaniline, Ethanolamine, Hydrazine, Triethanolamine, Dimethylformamide, Pyridine, Piperidine
Sulfur, Phosphorus Compound	Hydrogen	Hydrogen Sulfide, Tributyl Phosphate
Other Compound	Nickel Acetate, Lead Acetate, Zinc Acetate, Tetraethyllead, Vegetable Oil, Silicone Oil	Calcium Acetate, Nickel Acetate, Lead Acetate, Zinc Acetate
Inorganic Solvent	Hydrochloric Acid, Nitric Acid, Sulfuric Acid, Hydrobromic Acid, Phosphoric Acid, Hypochlorous Acid, Chromic Acid, Perchloric Acid, Sodium Hydroxide	Sodium Hydroxide, Aqueous Ammonia

**Do not put the foreign substances in the oven.**



Do not put a foreign substances such as metals or flammable substances in the opening of the unit (ventilation hole and exhaust port, etc.). If this procedure is not followed, fire, electrical shock or burn may result.



If the foreign substances enter the unit, turn off the circuit breaker immediately and contact a service technician for inspection. If this procedure is not followed, fire, electrical shock or burn may result.

**Caution in taking out a specimens**



During and immediately after operation, the internal surfaces of the chamber and the door are extremely "HOT." To prevent injury, take out the specimens when the chamber has cooled down or wear gloves while the chamber is still hot.

**When you open the door during working at the high temperature.**



Do not touch the internal surfaces of the chamber and the door when you will open the door, because they are extremely hot.



To open the door while the chamber is still hot may cause the malfunction of a fire detector if it is installed near the oven.

**Do not touch heated parts.**



Do not touch the door or the area around the observation window during or immediately after operation. Severe burning injury may be caused due to the high temperature.

**Do not climb on the oven**



Do not climb on top of the oven because it will fall down and break. Failure to observe this caution may cause injury to a person.

**Do not put anything on the oven**



Do not put anything on top of the oven because they will fall and result in injury to a person.

## Caution

---

### Caution about the temperature range.



- Model DP23/33 ovens should be used at temperature ranges from 40°C to 220°C and DP43/63 ovens should be used at temperature ranges from 40°C to 200°C. The temperature input range of DP23/33 is from 0°C to 260°C and the one of DP43/63 is from 0°C to 220°C.

### When you use the oven for the first time



During the initial operation, the oven may occasionally generate an odor especially when high temperatures are reached. This odor is normal and does not signal a problem with the oven. The nature of the odor is caused by the adhesive on the insulation melting.

### About the temperature in the chamber



The temperature outside the chamber is detected by a sensor that controls it. Therefore, the temperature of the sample does not always match the temperature measured by this sensor. The chamber temperature differs a great deal from the temperature measured immediately after opening and closing the door.

### Caution about a drenched specimen



- When using a very wet sample, try to drain it as much as possible before putting it in chamber.
- When using a sample containing a large quantity of water or sample containing an organic solvent, be sure to remove as much liquid evaporation as possible by using a trap. This will help to ensure the life span of the vacuum pump and vacuum oil.

### Caution about a powdery specimen and the loading of specimens



There are times when a powder sample is scattered by the sudden decompression operation or purge operation. When performing decompression or purge, open the valve very slowly.



It occasionally takes a long time before the chamber reaches the target temperature if the chamber is congested with specimens or a specimen with the large specific heat is in it. In such cases, reduce specimens. Moreover, note that the temperature display occasionally unsettles when you process an exothermic specimen.

### Do not place any samples on the bottom of the chamber



- Do not place any samples on the bottom of the chamber to heat, because it affects the temperature control of the oven.



- Always put the samples on the attached shelves. Place sample so that it does not touch the interior wall of the chamber.
- Set the shelves on the shelf brackets that will accommodate the size of the sample.

### Distribute specimens



- Each shelf can carry a uniform load of 15 kg (33 lb.). When you place specimens on a shelf, distribute them evenly over the shelf area.
- If a shelf is congested with specimens, the oven occasionally cannot regulate temperatures properly. To ensure the oven's temperature accuracy, there should be open space of at least 30% on each shelf.

### Precautions when stopping the vacuum pump



- If you stop the vacuum pump at an evacuated state, the oil in the pump may flow backwards inside the oven. Therefore, when stopping the vacuum pump after finishing the oven operation, first open the purge valve and the pump valve of the oven, then stop the vacuum pump.

### To keep the chamber being a vacuum



- To maintain a vacuum in the oven, leave the pump valve of the oven open to make the vacuum pump operate. If you leave the pump valve closed and stop the vacuum pump, there may be times when the pump oil will flow backwards in the exhaust pipe.

### During a thunder storm



During a thunder storm, turn off the power key immediately, then turn off the circuit breaker and main power. If this procedure is not followed, fire or electrical shock may be caused.

### when having a blackout



Once the power supply is recovered, the oven can resume when it stopped because of having a blackout.

### Do not place specimens on the bottom plate.



Do not place any samples on the bottom of the chamber to heat, because it affects the temperature control of the vacuum oven.

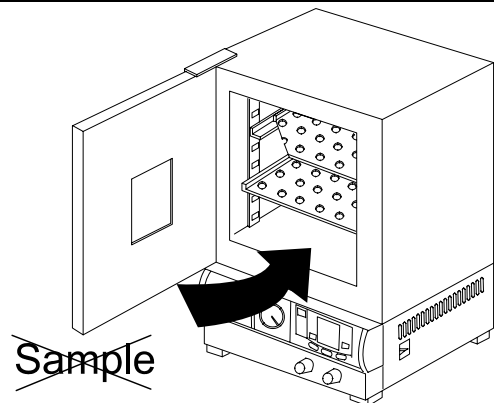

### Never use corrosive specimens



Most parts are made of stainless steel (SUS304). However, strong acid occasionally corrodes even stainless steel. Besides this, the silicone rubber packing is also vulnerable to acid, alkali, oil and halogens' solvents

### When you open and shut the door



Do not put your hand either face near the door when you open and shut the door. Failure to observe this caution may result in injury because the door hits your hand or face.

# Operating Procedure

When prepared completely, proceed as follows:

## 1. Turning on of power supply

- Turn on the circuit breaker.



- The present time is shown on the sub display.



- Push the POWER key in the operation panel.

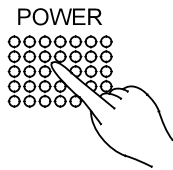

- When once the power is on, this oven becomes a standby state. Under such a condition, every operation mode can be selected by pushing the MENU key.

## 2. Selection of operation menu

- Press the MENU key several times to select desired operating method.

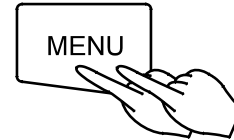

- It allows you to enter each parameter into a flashing menu.

## 3. Explanation of operation menu

- |                   |   |
|-------------------|---|
| Fixed Temperature | : It is a operation method to bring the oven to the desired temperature and keep it steady.   |
| Auto stop         | : It is a operation method to stop a fixed temperature operation when reached the set time or hours.  |
| Auto start        | : It is a operation method to start the fixed temperature operation when reached the set time or hours.   |
| Program           | : It is a operation method that can start or stop a operation either when reached the set time or hours. Moreover, it can change the temperature when reached the desired time and repeat to do that. |

# FIXED TEMPERATURE OPERATION INSTRUCTIONS

## Selection of operation menu

- Push the MENU key and select the fixed temperature operation.

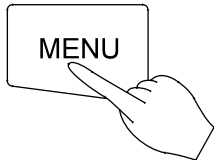

Push the MENU key.

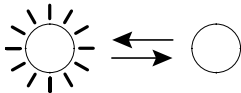

The lamp of the FIXED TEMP blinks.



- The temperature set last time is blinking and enters the state that a set temperature can be input in a sub-display.

## Input of set temperature

- Push the ENTER key after making a sub-display display an arbitrary set temperature pushing ▲▼ keys.

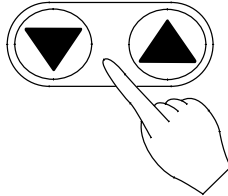

Press either the ▲ key or the ▼ key several times. Then, the desired set temperature will appear on the main display.

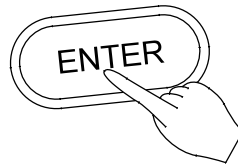

Press the ENTER key.

- The vacuum oven will start to run the fixed temperature operation to the renewed temperature.

## Changing the set temperature when fixed temp operation is in progress

- Push either the ▲ key or the ▼ key to display the desired temperature on the main display and push the ENTER key.

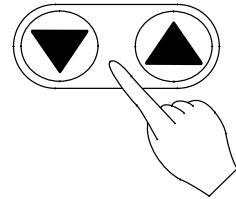

Press either the ▲ key or the ▼ key several times. Then, the desired set temperature will appear on the main display.



Push the ENTER key.

- The vacuum oven will start to run the fixed temperature operation to the renewed temperature.

# AUTO START OPERATION INSTRUCTIONS

## Selection of operation menu

- Select AUTO START mode by pushing the MENU key.

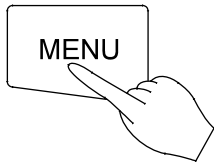

Push the MENU key.

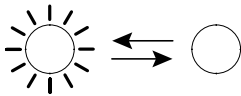

The operation menu lamp of an AUTO START blinks.



- **TEMP** will appear on the sub display and the desired temperature can be input.

Sub display



## Inputting the set temperature

- Press either the ▲ key or the ▼ key to display the desired temperature on the main display and push the ENTER key.

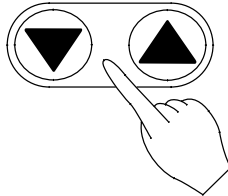

Press either the ▲ key or the ▼ key several times. Then, the desired set temperature will appear on the main display.

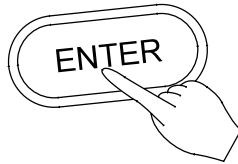

Press The ENTER key.



- **TIME** will appear on the sub display and the operation start time can be input.

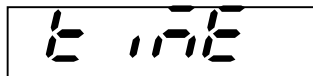

## Inputting the desired set time

- Press either the ▲ key or the ▼ key to blink start time (or the hour) on the main display, and press the ENTER key.

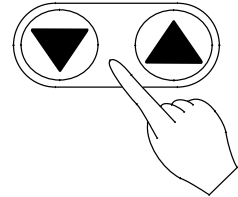

Press either the ▲ key or the ▼ key several times. Then, the desired start time(or hour) will appear on the main display.

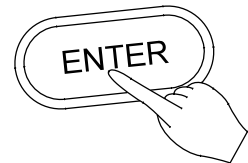

Press the ENTER key.

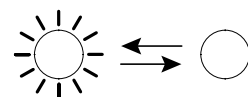

- The STANDBY lamp of the operation monitor blinks.
- The operation will be in standby condition.
- After reaching the set time (or hour), the vacuum oven will start to run the auto start operation to the renewed temperature.

# Auto Stop Operation Method

## Selection of operation menu

- Press the MENU key and select the auto stop operation.

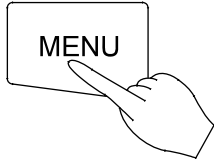

Press the MENU key.

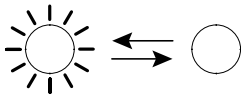

The menu lamp of an AUTO STOP blinks.



- **LEAP** will appear on the sub display and the desired temperature can be input.

Sub display

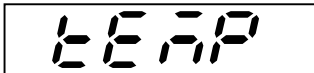

## Inputting the set temperature

- Push either the ▲ key or the ▼ key to blink the desired temperature on the main display and push the ENTER key.

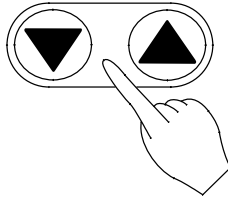

Press either the ▲ key or the ▼ key several times. Then, the desired set temperature will appear on the main display.

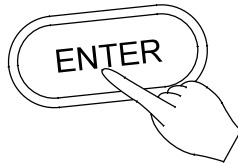

Push the ENTER key. The main display will light up to indicate the set temperature you have chosen.



After about 1 second

- **t 17.5** will appear on the sub display and the operation stop time can be input.

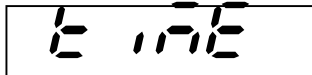

## Inputting the desired set time

- Push either the ▲ key or the ▼ key to blink your desired time (or hours) for operation stop on the main display, and press the ENTER key.

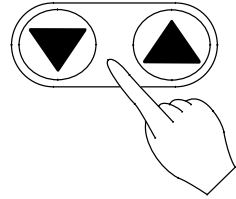

Press either the ▲ key or the ▼ key several times. Then, the desired stop time (or hour) will appear on the main display.



Push the ENTER key.



- **0A 12** will appear on the sub display and you can chose the wait function to be activate or not.

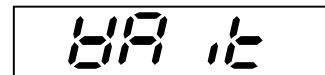



## Selection of wait function

- Press either the ▲ key or the ▼ key to indicate the wait function (ON or OFF) on the main display. Then press ENTER key.

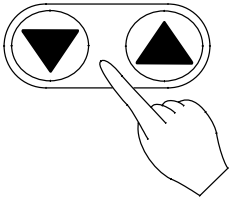

Press either the ▲ key or the ▼ key several times.  
Either ON or OFF will appear on the main display.

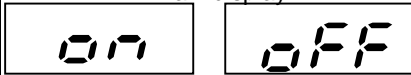

(activate)

(inactive)



Press the ENTER key.



- This operation activates the auto stop operation.

## Working conditions of timer

- Auto Stop timer activates when: .

1. The wait function is on.



**It starts when the set temperature has reached the target value.**

2. The waiting function is off or the time setting represents hours.



**It starts right after the auto stop operation is started.**

# Programmed Operation Method

## Selection of operation menu

- Press the MENU key and select the programmed operation..

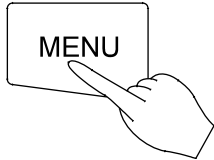

Press the MENU key.

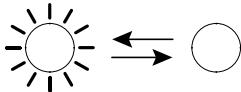

The operation menu lamp of the PROGRAM blinks.



- **Pr 00** will appear on the sub display and the execution program number can be input.



## Input of execution program number

- Press either the ▲ key or the ▼ key to indicate an desired program number on the main display, and press the ENTER key.

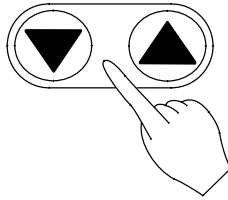

Press either the ▲ key or the ▼ key several times.

The program number will appear on the main display.

**NOTE:** If no programs have been set, \_\_\_\_\_ is blinking.

See the Operating Instructions for Programmable Controller to set a new program.

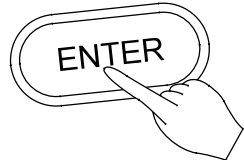

Push the ENTER key.



- **t 11E** will appear on the sub display and the operation start time can be input.

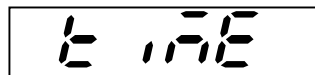

## Input of time

- Press either the ▲ key or the ▼ key to blink your desired operation start time (or hour) on the main display, and press the ENTER key.

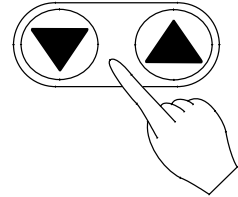

Press either the ▲ key or the ▼ key several times.

The desired set time will appear on the main display.



Push the ENTER key.

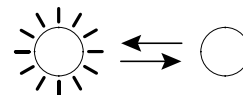

- The standby lamp on the operation monitor blinks. (Operation is in STANDBY MODE)
- The operation will start after the set time is up.

**NOTE :** Both the DP23 and DP33 do not have the program operation mode.

## SWITCHING FROM ONE OPERATION TO ANOTHER

This instrument can switch to a different operation mode without stopping the current program no matter what mode it is in, fixed temperature operation, auto-start/stop operation, and program operation.

### Selection of operation menu

- Press the MENU key several times until the desired operation menu lamp flashes on the Operation Menu.
- Since the current operation has not stopped, the operation menu lamp is also lit.
- On the Operation monitor -- the temperature pattern indicator lamp blinks with the current segment being executed.

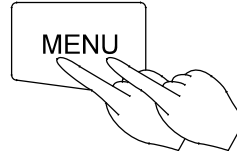

Press MENU key several times.



- This status allows you to enter each parameter into blinking or lighting operation menu.

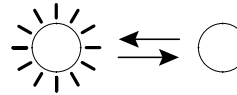

#### When the fixed temperature operation is selected

- The main display shows the current internal temperature.
- The sub-display flashes the temperature set by the previous fixed temperature operation.

#### When auto-start operation is selected

- The main display flashes the temperature set by the previous auto-start operation.
- The sub-display shows **TEMP** (Temp.)

#### When auto-stop operation is selected

- The main display flashes the temperature set by the previous auto-stop operation.
- The sub-display shows **TEMP** (Temp.)

#### When program operation is selected

- The main display flashes the previously set program number.
- The sub-display shows **PRG** (Program)

The lamp blinks or lights.



- Now operate according to the operation method you have chosen, see that section of this instruction manual.

## Method of using DISPLAY key

The display content of the sub display can be changed over by turns when pushed the DISPLAY key.

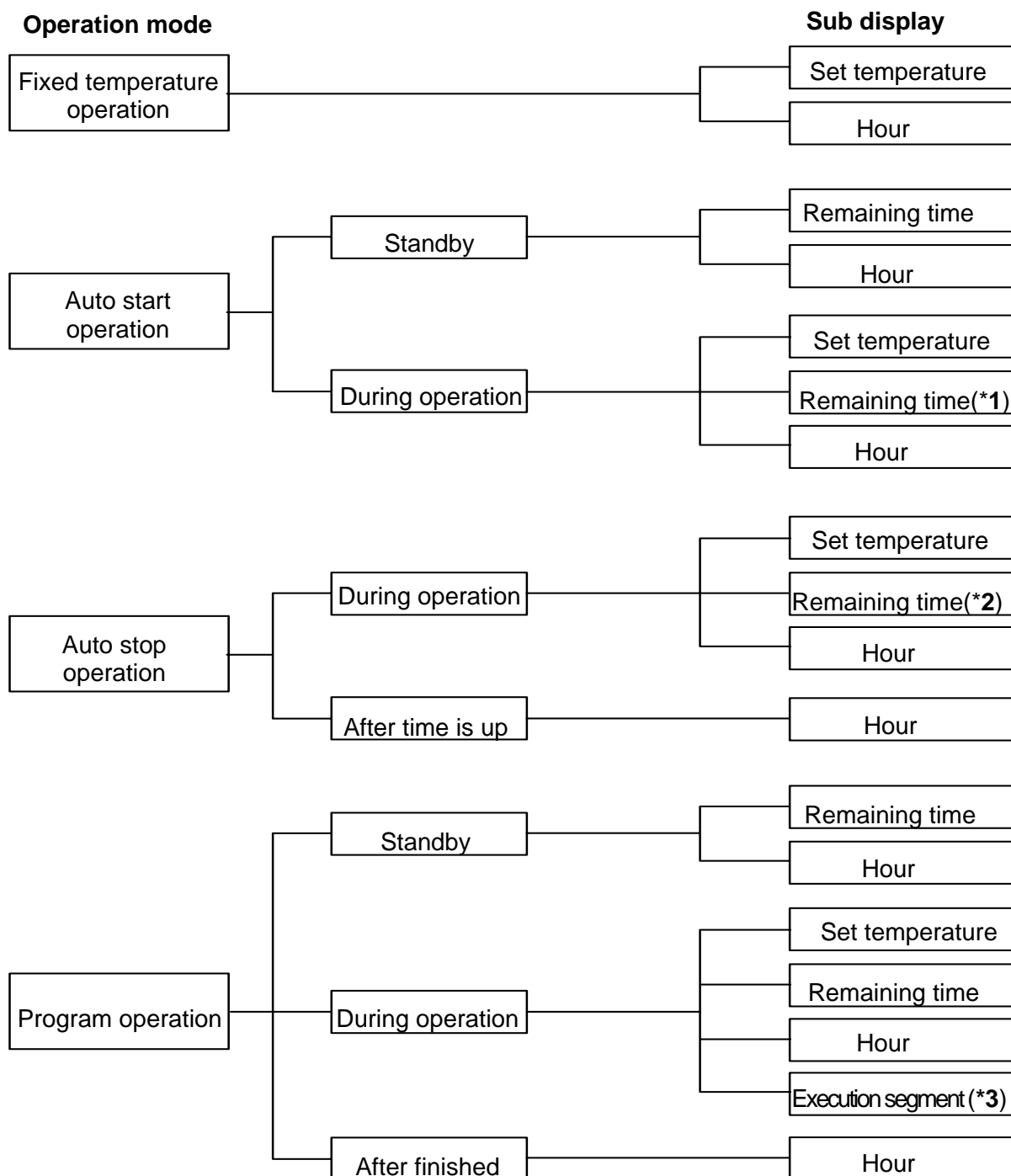

\*1 : HOLD is displayed.

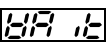
\*2 : When the wait function is set to on,  is displayed in the waiting status.

\*3 : During repeat operation, the rest of the repeat count can be displayed by the DISPLAY key.

## Usage of MODE

### Content of function menu

In addition to the functions shown previously, this unit's controller also incorporates the following functions.

- Press the MODE key to display any of the following function menus on the main display. The menus can be brought up one by one with ▲▼ keys.

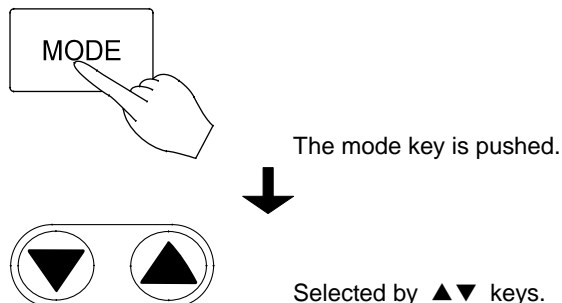

Main display	Function	
<i>comL</i>	Communication lockout	It is a function to select whether to respond to it when there is a communication demand from the host computer connected via the communication interface.
<i>cl oH</i>	Date and current hour setting function.	To set the date and hour.
<i>Pr oG</i>	Program inputting and editing function	To input and edit the program.
<i>deLP</i>	Program deleting function.	To delete existing programs that are no longer necessary. Confirmation of the program contents should be performed prior to deleting and in accordance with Programmed Operation Method.
<i>t iNE</i>	Hour/time setting mode select function.	To input either an hour or a period of time during time setting process in the various operation modes -- auto-start/stop, and program operation. It is set to the time (a period of time) setting mode when the product was shipped from the factory.
<i>LoCK</i>	Key lock setting/resetting function.	To set or reset the key lock function that locks the <b>POWER</b> , <b>MENU</b> , <b>ENTER</b> , and <b>DELETE</b> keys on the operation panel to prevent incorrect entries from the panel during operation or while in the standby mode. If the key lock function is set, the <b>KEY LOCK</b> lamp on the operation monitor is lit.
<i>beEP</i>	Alarm buzzer ON/OFF function.	To select whether or not to activate the alarm buzzer when an error occurs.
<i>Accñ</i>	Accumulated time display function	To display the total duration that the <b>POWER</b> key is on, within the range of 0 to 49999 hours.
<i>Hold</i>	Hold function	To hold the operation that is currently running. This function is active only when operating in auto-start/stop or program operation mode (including the standby condition), or during the setting of the operation start time for auto-start or program operations as well as the operation end time for auto-stop are set in the form of "Time" and not in the form of "Hour."

# Calibration Offset Function

## Outline of Function

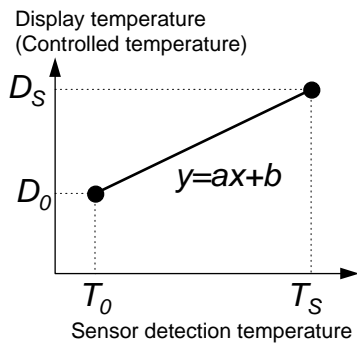

**Fig. 1**

In the controller, the relationship between the temperature  $T$  detected by the sensor and the display temperature of the operation panel  $D$  is expressed by the equation of the line which passes the two points  $(T_0, D_0)$  and  $(T_S, D_S)$  shown in Fig. 1.

Here,  $T_0$  is the sensor detecting temperature when the chamber central temperature becomes the zero adjusting temperature (normally room temperature is adopted)  $D_0$  at the time of no load,  $T_S$  is the sensor detecting temperature when the chamber central temperature becomes the span adjustment temperature (normally working maximum temperature is adopted)  $D_S$  at the time of no load in the same way.

As it is clear from the facts above, conforming of the chamber central temperature and the display temperature is guaranteed only when there is no load and at two points shown above. In other words, it is

possible for a temperature measured at a point in the chamber does not conform to the display temperature of the operation panel at a voluntary temperature without load.

This is the function to move the line which passes above two points to the Y axis direction in parallel (increase or decrease y intercept of the line). The parallel movement amount including a sign is defined as the calibration offset. This function can conform the display temperature of the operation panel to the measurement temperature of a voluntary point in the chamber at a voluntary temperature.

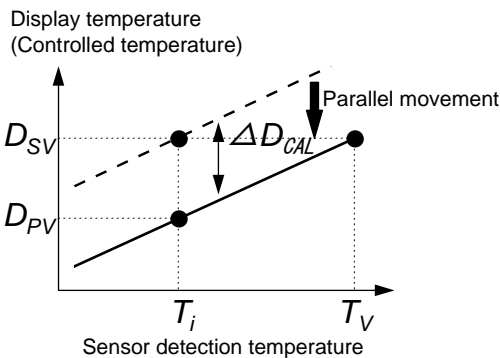

**Fig. 2**

In Fig. 2,  $D_{SV}$  is a display temperature of the operation panel under the condition that the temperature in the chamber is constant for a set temperature. It is natural to say that this value is equal to the target set temperature.  $D_{PV}$  is a measurement temperature of a voluntary point in the chamber under this condition. The difference between  $D_{PV}$  and  $D_{SV}$  including the sign is defined as the calibration offset. Therefore offset is shown as below.

$$\Delta D_{CAL} = D_{PV} - D_{SV} \quad \text{Equation 1}$$

In Fig. 2,  $\Delta D_{CAL}$  becomes the negative value since the target set temperature  $D_{SV}$  is larger than the actually measured temperature  $D_{PV}$ .

In order to conform the display temperature to the actually measured temperature, let the controller to recognize that the temperature in the chamber differs from the target set temperature by  $\Delta D_{CAL}$ .

### NOTE: Setting Tolerance of Calibration Offset

- ◆ In case of the DP23/33, you can set the calibration offset within range of  $\pm 13^\circ\text{C}$ .
- ◆ In case of the DP43/63, you can set the calibration offset within range of  $\pm 11^\circ\text{C}$ .
- ◆ Initial value on shipping is set to  $0^\circ\text{C}$ .

## Setting The Calibration Offset Function

This function can be activated when the controller is in the condition of accepting the MODE key.

- EX.** Bring the oven to the target set temperature 100°C and allow it to reach the steady state.. After then measure the temperature at a point in the chamber. If it shows 97°C when the main display shows 100°C, you can conform your measuring value to the one on the display by using the calibration offset function.

Calibration offset  $\Delta D_{CAL}$  is obtained from the

Equation 1 (page27) as shown below.

$$\Delta D_{CAL} = 97^{\circ}\text{C} - 100^{\circ}\text{C} = -3^{\circ}\text{C}$$

Procedures to set the calibration offset  $\Delta D_{CAL}$  to the controller are shown as below.

### Setting and changing the calibration offset value

- Push the MODE key, and then push the ▲ key or the ▼ key several times to display CAL on the main display.

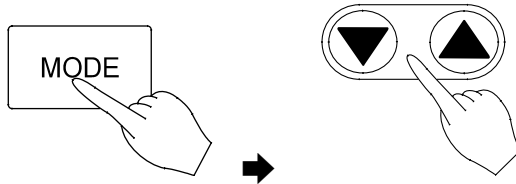

Push the ▲ key or the ▼ key several times

- The sub display shows the calibration offset value that has been set the last time.

**NOTE: When the unit is shipped from the factory, the sub-display shows 0 as the calibration offset value.**

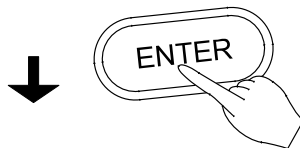

Push the ENTER key.

- The main display flashes the preset calibration offset value.
- ⇒ In this state, the set value of the calibration offset can be changed.
- The sub display shows CAL.

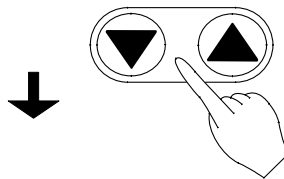

Push the ▲ key or the ▼ key several times

- Push either the ▼ key or the ▲ key to change the value on the main display to your desired value (calibration offset value to be set newly).



When the changing is completed, push the ENTER key.

- The changed value is entered and both the main and the sub displays return to the display mode just before pushing MODE key. The controller starts the temperature controlling operation in order to make the difference zero, since the difference is generated between the target set temperature and the temperature in the chamber by the changing of the calibration offset value.

## Safety Devices and Error Codes

### Purposes and Operations of Safety Device and Counter-measures

This instrument incorporates an automatic diagnosis function built in the controller and safety devices independent of the controller. The purposes and operations of the safety devices and countermeasures are shown in the **Table** below. When an abnormal condition occurs, an error code is displayed in the main display. Immediate action should be taken according to the specific counter-measures.

Safety Device	Display	Cause & Counter-measures
1. Circuit breaker	No Display	<ul style="list-style-type: none"> <li>Power circuit interrupted</li> <li>Erases all displays</li> </ul> ⇒ Report to our service office and check the cause of the problem.
2. Sensor malfunction detector	<b>TROUBLE</b> lamp flashes. <i>Er.01</i> flashes.	<ul style="list-style-type: none"> <li>Break in temperature sensor circuit.</li> </ul> ⇒ Report to our service office.
3. Triac circuit detector	<b>TROUBLE</b> lamp flashes <i>Er.02</i> flashes.	<ul style="list-style-type: none"> <li>Short circuit in triac.</li> </ul> ⇒ Report to our service office.
4. Disconnected heater circuit detector	<b>TROUBLE</b> lamp flashes <i>Er.03</i> flashes.	<ul style="list-style-type: none"> <li>Heater circuit is disconnected.</li> </ul> ⇒ Report to our service office.
5. Independent overheating prevention	<b>TROUBLE</b> lamp flashes <i>Er.07</i> flashes.	<ul style="list-style-type: none"> <li>Incorrect setting of the independent overheating prevention.</li> </ul> ⇒ Set correctly. <ul style="list-style-type: none"> <li>Heating of sample</li> </ul> ⇒ Reduce the amount of the sample. <ul style="list-style-type: none"> <li>Malfunction of the independent overheating prevention circuit.</li> </ul> ⇒ Report to our service office.
6. Main relay malfunction detector	<b>TROUBLE</b> lamp flashes <i>Er. 10</i> flashes.	<ul style="list-style-type: none"> <li>A malfunction of the main relay.</li> </ul> ⇒ Report to our service office.
7. POST function*	<b>TROUBLE</b> lamp flashes <i>Er08</i> , <i>Er14</i> , <i>Er15</i> flashes.	<ul style="list-style-type: none"> <li></li> </ul>
8. Automatic overheating preventive function	No Display	<ul style="list-style-type: none"> <li>Heating of samples</li> </ul> ⇒ Reduce amount of samples
9. Key lock	Key lock display lamp lights up	<ul style="list-style-type: none"> <li>This function prevents the disruption of operation due to incorrect operation. Leave it on during operation. (See section in this manual for setting and resetting methods).</li> </ul>
10. Memory backup circuit	No Display	⇒

\* **POST (Power On Self Test)** function checks the microprocessor, memory surrounding LSI, surrounding circuit of the controller every time “**POWER**” key is turned **ON**. This function checks that there are no fatal malfunction of the controller before starting the operation.



## INDEPENDENT OVERHEAT PREVENTION

There are two safety devices in this unit: the auto-overheating preventive function of the controller (automatic recovery) and the independent overheating prevention (manual recovery). They are configured by circuits and sensors that are independent from the controller. These safety devices for the temperature overheating prevention protects the instrument in a fail-safe method.

### Setting the Temperature Range and Function

<b>Setting Temperature:</b>	0 to 399°C
<b>Input Method:</b>	Three integer digital switch. Turn the drum of each column and set the desired value. The first integer can only be from 0 to 3 for the hundred column.
<b>Function:</b>	Heater output is cut off when the measured temperature gets higher than the set temperature of the independent overheating prevention. The function is active when the circuit breaker is ON. When the independent overheating prevention is activated, is flashing on the main display with the <b>TROUBLE</b> lamp flashes. When the independent overheat prevention is active while the heater is in the temperature rising process, etc., and flash alternately on the display.

### Activation/Setting Method

1. Set the independent overheating prevention 15°C higher than the set temperature of the main unit.
2. When setting the proper value to protect the sample, be sure it is well above room temperature, and set it at least 15°C higher than the maximum temperature set value of the temperature pattern of the program.
3. When the independent overheating prevention is activated improperly by changing the setting of the independent overheating prevention lower than the internal temperature or by continuing operation when the setting on the unit is too low, turn off the circuit breaker to reset the unit and perform the setting again. If it is activated by another reason, see Safety Devices and Error Codes in the this manual.

### Precautions

1. Only 0 to 3 can be set for the column of hundreds of the digital switch by the stop mechanism; however, if forced to change it to a value higher than 3, it will damage the unit.
2. Set temperature can change by touching the setter when cleaning. Always confirm that the set temperature is correct after cleaning or before operation.

## Maintenance and Inspection

### Warning

#### Do not disassemble and modify the oven.



- Do not disassemble the oven. There are parts in the unit with high voltage; therefore, if the unit is disassembled, electric shock and injury may result. Ask the Yamato Scientific office for inspection, adjustment, and repair of the inside of the unit.
- Unauthorized modification will be hazardous and cause problems in the operation of the Oven..

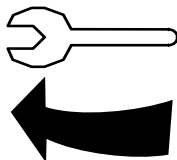
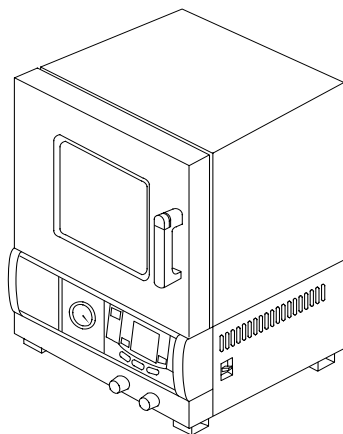

~~Modification~~

### Caution

#### Maintenance Precautions



- Before starting inspection or maintenance, disconnect the power plug from the receptacle.
- Conduct inspection and maintenance only after the oven has cooled down.
- When you remove dirt or stains from the unit's resin parts and the control panel, use a soft wet cloth. Do not use benzene, thinner, cleanser or a hard brush; it will cause deformation, qualitative deterioration and/or discoloring of the components.

#### Periodic inspection of the safety component.(Only DP43/63)



- The independent temperature over-rise prevention device is important safety component. Be sure to inspect it periodically.(See chapter on Maintenance Procedure on page )

#### Monthly servicing of vacuum pump oil



- At least once a month, check the oil gauge of the vacuum pump and replenish the oil as needed. Because the oil deteriorates during use, check the oil and replace it periodically. For oil replacement, refer to the instruction manual of the vacuum pump.

If you have any questions, contact our sales representative in your vicinity or our service office.

## Maintenance Procedure

### Operation Check of Independent Temperature Overheating Prevention Device

- After executing the fixed temperature operation at the set temperature 0°C, set the operation temperature of the Independent Temperature Overheating Prevention Device to 0°C.
- Under normal circumstances, the heater circuit is cut off in a few seconds and the **TROUBLE** lamp and *E-07* flashes at the same time, and the alarm buzzer sounds if the alarm buzzer function is ON.
- After confirming, turn off the circuit breaker once, then return the setting of the Independent Temperature Overheating Prevention Device to the proper value. Turn the circuit breaker back ON.



Always perform inspection before a long continuous operation or an unattended operation.

## Long Storage and Disposal

### When you do not use the oven for a long period of time.



Disconnect the power plug from the receptacle.

### When you dispose of the oven.



Do not leave it where children can access. Remove the knob and hinges of the door to disable the door locking system.

## After service and WARRANTY

### If a Service Call is required:

#### If a Service Call is required

- If a problem occurs with the Drying Oven, record the error code on the display and stop the operation immediately, turn off the power switch, and disconnect the power plug from the receptacle. Contact our sales or service representative.
- Check the warranty card or the name plate of your Drying Oven and give us the information below.
  - Model of your oven;
  - Serial product number of your oven;
  - Date of purchase; and
  - Problem with your oven (as detailed as possible).

#### Warranty Card (attached to your Oven)

- Please fill out completely and return the bottom portion of the warranty card when the unit is received. The completed top portion is your Registration Card that should be retained for your records.
- Warranty period is one (1) year after the date of your purchase. During this warranty period, we will offer free repair service on the basis of the conditions provided on the warranty card.
- If you need repair service after expiration of the warranty period, contact our sales or service representative in your vicinity or service office for advice.

#### Minimum Inventory Period of Repair Parts

Repair parts will be available for at least 5 years after termination of our production of DP Drying Oven Series. Repair parts mean the parts that are necessary to maintain the performance of the ovens.

## TROUBLESHOOTING

Problem	Cause/Solution
No display of current hour in the sub-display at the activation of the circuit breaker.	<ul style="list-style-type: none"> <li>• Check if the power cable is firmly connected to a receptacle.</li> <li>• Check for power failure.</li> </ul>
Temperature fluctuates during the operation	<ul style="list-style-type: none"> <li>• Does ambient temperature fluctuate violently?</li> <li>• Are there too many specimens in the chamber?</li> <li>• Are the specimens too moist?</li> </ul>
It takes a lot of time to form a vacuum in the chamber.	<ul style="list-style-type: none"> <li>• Do you keep the pump valve opened or the purge valve closed?</li> <li>• Check vacuum pump connection for leaks. In case of defective vacuum hose, replace it.</li> <li>• Has the pump oil been deteriorating? (Refer to instruction manual of vacuum pump.)</li> </ul>

# SPECIFICATIONS

Model	DP23	DP33	DP43	DP63
Method	Vacuum drying by decompressed chamber direct heating			
<b>Performance:</b>				
Operating temperature	40°C to 240°C		40°C to 200°C	
Operating pressure range	101 to 0.1 kPa (760 to 1 Torr)			
Temperature stability* <sup>1</sup>	±1.5°C (at 240°C)		±1°C (at 200°C)	
Time to reach max. temp.* <sup>1</sup>	Approx. 60 min.	Approx. 90 min.	Approx. 80 min.	Approx. 120 min.
<b>Structure:</b>				
Exterior	Cold rolled steel plate with baked-on melamine resin finish			
Interior chamber	Stainless steel (SUS304)			
Insulating material	Rock wool			
Door	Single swing door			
Heater nominal capacity	0.68kW	1.05kW	2.25kW	3.15kW
Vacuum gauge	Bourdon tube type, 0 to 0.1MPa			
Observation window	Tempered glass covered with polycarbonate resin plate			
Vacuum connecting port	φ18 mm		NW25 flange	
Purge port	φ18 mm		RC1/4	
<b>Controller:</b>				
Temperature control method	PID control by microprocessor			
Temperature setting method	Digital setting method by ▲▼ keys (resolution: 1°C)			
Temperature indicating method	Digital indication by green LED (resolution: 1°C)			
Other indication	Temperature pattern LED indication that shows operation indication			
Timer	1 min. to 99 hrs. 59 min. or 100 hrs to 999 hrs (timer resolution: 1 min. or 1 hr.)			
Operation function	Fixed temperature operation Auto-start/Auto-stop operation		Fixed temperature operation Auto-start/Auto-stop operation Program operation (16 segments, repeat, etc.)	
Additional function	Calendar timer function (actual hr. timer within 24 hrs.) Integrating time function (Integrated hr. up to 49999 hrs. can be measured.) Time indication (The present time is indicated.) Calibration Offset Function			
Heater circuit control	Triac zero cross system			
Sensor	K thermocouple (double sensor)			
Safety device	Short circuit breaker Self-diagnostic function (sensor abnormality, heater disconnection and Triac short circuit detection; automatic temperature over-rise prevention) Key lock function Independent Temperature Overheat Prevention device (Digital switch input system, setting temperature range: 0 to 399°C)			
Inside dimensions (WxDxH)* <sup>2</sup>	17.7"x17.7"x17.7"		23.6"x23.6"x23.6"	
Overall dimensions (WxDxH)* <sup>2</sup>	26.4"x26.3"x59.1"		32.3"x32.2"x65.0"	
Capacity	0.35 cu ft	0.95 cu ft	3.2 cu. ft.	7.6 cu. ft.
Weight	Approx. 95 lbs.	152 Approx. lbs.	Approx. 419 lbs.	Approx. 639 lbs.
Power Requirements	AC 115V, 50/60Hz, 6A	AC 115V, 50/60Hz,9.5A	AC 220 V, 50/60Hz,10.5A single phase	AC 220 V, 50/60Hz,14.5A single phase
<b>Accessories:</b>				
Shelf	Punched stainless steel, 2 pcs.			
Instruction manual	For exclusive use of this oven and the controller: each one			

**NOTES:** \*1. Value at the time of no sample and ambient temperature of 20°C (Time required to reach maximum temperature conforms to our standards.

\*2. Inside and overall dimensions do not include protruding parts

# WIRING DIAGRAM

(DP23/33) - AC 115V

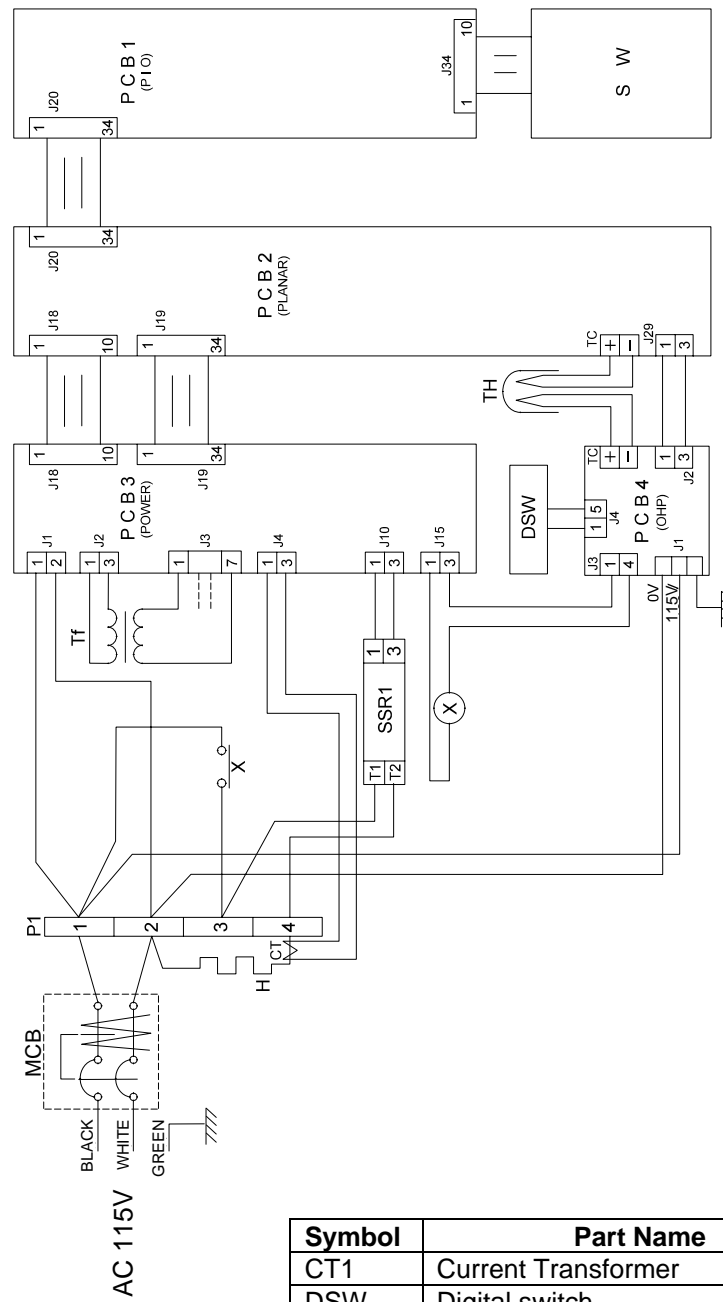

Symbol	Part Name
CT1	Current Transformer
DSW	Digital switch
H	Heater
MCB	Circuit Breaker
P1	Terminal block
PCB1	PIO board
PCB2	PLANAR board
PCB3	POWER board
PCB4	Independent overheat prevention
SSR1	Solid-state relay
SW	Membrane keypad
Tf	Transformer
TH	Thermocouple(double sensor)
X1	Relay

**(DP43/63) - AC 220V**

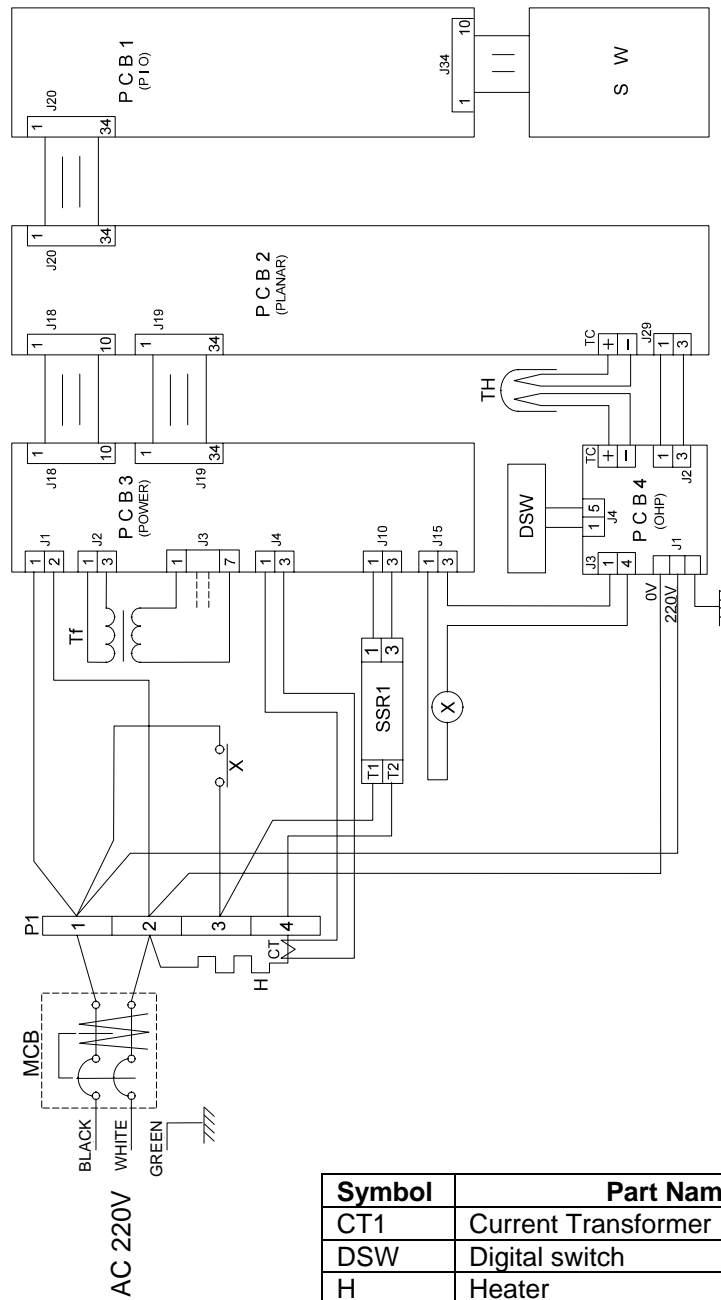

Symbol	Part Name
CT1	Current Transformer
DSW	Digital switch
H	Heater
MCB	Circuit Breaker
P1	Terminal block
PCB1	PIO board
PCB2	PLANAR board
PCB3	POWER board
PCB4	Independent overheat prevention
SSR1*1	Solid-state relay
SW	Membrane keypad
Tf	Transformer
TH	Thermocouple(double sensor)
X1	Relay

\*1 DP63 has two SSR1.



# HEATER DETAILS

## Heater Structure of Model DP23/33

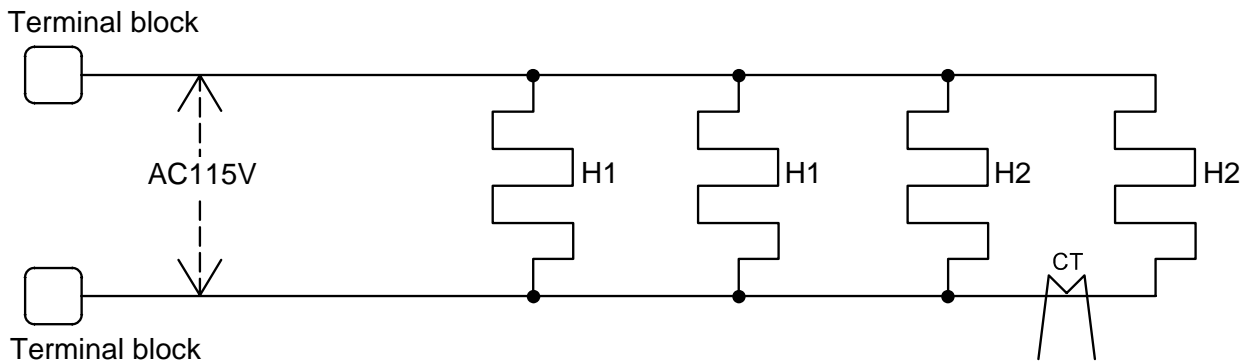

## Heater Structure of Model DP-43

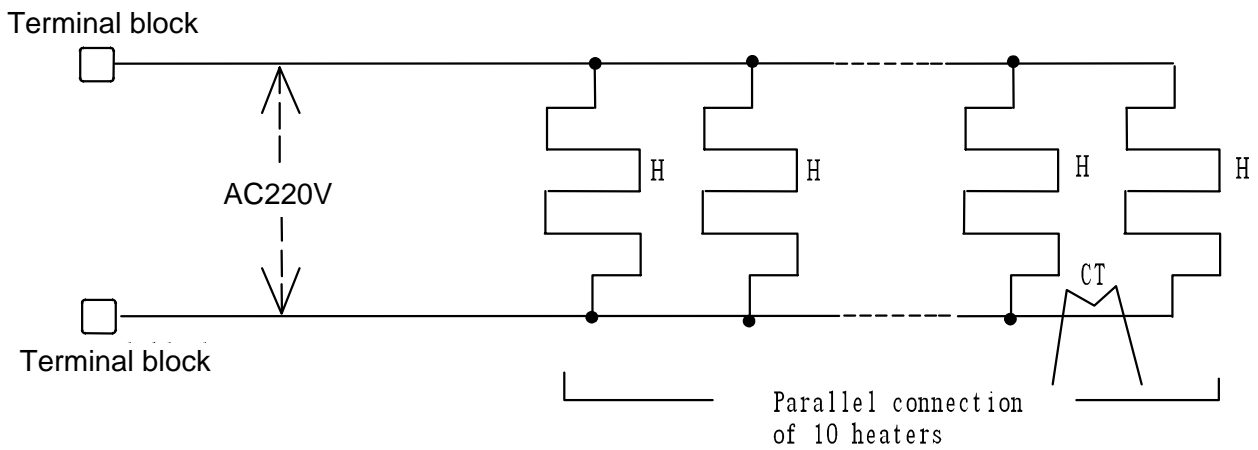

## Heater Structure of Model DP-63

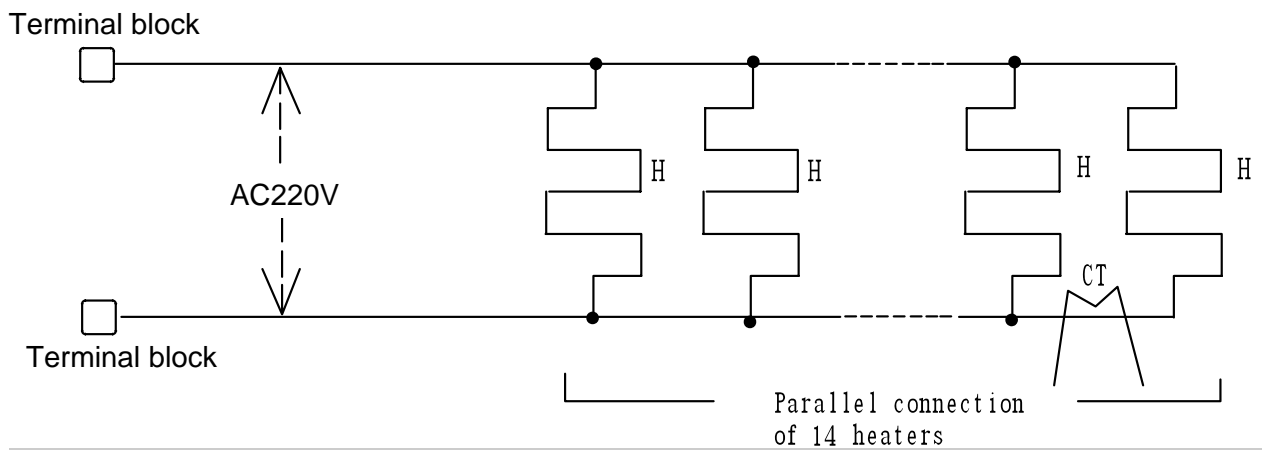

## REPLACEMENT PARTS TABLE

### DP23

Symbol	Part Name	Code No.	Specifications
CT1	Current Transformer	2-17-001-0002	CTL-6-S-400
H1	The upper heater	DP22B-40500	115V, 80W
H2	The side and the bottom heater	DP22B-40510	115V, 200W
MCB	Circuit breaker	2-06-000-0007	BS2021
	Power code	2-13-001-0005	T2 - 3b
P1	Terminal block	2-07-023-0001	M011-0FX 4P
PCB1	PIO board	1-24-000-0024	
PCB2	PLANAR board	1-24-000-0033	
PCB3	Power board	1-24-000-0025	Type 1
PCB4	Independent overheat prevention	1-24-000-0093	TB31-04-Z07
SSR1	Solid-state relay	2-16-000-0010	YLT-SSR-01
SW	Membrane keypad	1-01-320-0006	Type 3H
Tf	Transformer	2-18-000-0026	AC115V
TH	Thermocouple	1-16-001-0026	K thermocouple (double sensor)
X1	Relay	2-05-012-0001	JR1aF-TM-DC12V

### DP33

Symbol	Part Name	Code No.	Specifications
CT1	Current Transformer	2-17-001-0002	CTL-6-S-400
H1	The upper heater	DP32B-40500	115V, 150W
H2	The side and the bottom heater	DP32B-40510	115V, 300W
MCB	Circuit breaker	2-06-000-0007	BS2021
	Power code	2-13-001-0005	T2 - 3b
P1	Terminal block	2-07-023-0001	M011-0FX 4P
PCB1	PIO board	1-24-000-0024	
PCB2	PLANAR board	1-24-000-0033	
PCB3	Power board	1-24-000-0025	Type 1
PCB4	Independent overheat prevention	1-24-000-0093	TB31-04-Z07
SSR1	Solid-state relay	2-16-000-0010	YLT-SSR-01
SW	Membrane keypad	1-01-320-0006	Type 3H
Tf	Transformer	2-18-000-0026	AC115V
TH	Thermocouple	1-16-001-0026	K thermocouple (double sensor)
X1	Relay	2-05-012-0001	JR1aF-TM-DC12V

**DP43**

<b>Symbol</b>	<b>Part Name</b>	<b>Code No.</b>	<b>Specifications</b>
CT1	Current Transformer	2-17-001-0002	CTL-6-S-400
H1	Heater	DP41B-40500	220V, 225W
MCB	Circuit breaker	2-06-000-0006	BS2022
	Power code	2-13-001-0009	T2 - 3c-0
P1	Terminal block	2-07-023-0001	M011-0FX 4P
PCB1	PIO board	1-24-000-0024	
PCB2	PLANAR board	1-24-000-0033	
PCB3	Power board	1-24-000-0025	Type 1
PCB4	Independent overheat prevention	1-24-000-0093	TB31-04-Z07
SSR1	Solid-state relay	2-16-000-0010	YLT-SSR-01
SW	Membrane keypad	1-01-320-0006	Type 4H
Tf	Transformer	2-18-000-0027	AC220V
TH	Thermocouple	1-16-001-0026	K thermocouple (double sensor)
X1	Relay	2-05-012-0001	JR1aF-TM-DC12V

**DP63**

<b>Symbol</b>	<b>Part Name</b>	<b>Code No.</b>	<b>Specifications</b>
CT1	Current Transformer	2-17-001-0002	CTL-6-S-400
H1	Heater	DP41B-40500	220V, 225W
MCB	Circuit breaker	2-06-000-0006	BS2022
	Power code	2-13-001-0010	T3 - 3d
P1	Terminal block	2-07-023-0001	M011-0FX 4P
PCB1	PIO board	1-24-000-0024	
PCB2	PLANAR board	1-24-000-0033	
PCB3	Power board	1-24-000-0025	Type 1
PCB4	Independent overheat prevention	1-24-000-0093	TB31-04-Z07
SSR1	Solid-state relay	2-16-000-0010	YLT-SSR-01
SW	Membrane keypad	1-01-320-0006	Type 4H
Tf	Transformer	2-18-000-0027	AC220V
TH	Thermocouple	1-16-001-0026	K thermocouple (double sensor)
X1	Relay	2-05-012-0001	JR1aF-TM-DC12V

## Reference

### HAZARDOUS MATERIAL

Explosives	Explosives Substances	1. Nitroglycol, Nitroglycerin, Nitrocellulose, and other explosive nitric esters.
		2. Trinitrobenzens, Trinitrotoluene, Picric acid, and other explosive nitro compounds.
		3. Peracetic acid, Methyl ethyl ketone peroxide, Benzoyl peroxide, and other organic peroxides.
Flammables	Combustible Substances	Metallic lithium, Metallic potassium, Metallic sodium, Yellow phosphorus, Phosphorus sulfide, Red phosphorus, Celluloid, Calcium carbide, Lime phosphate, Magnesium powder, Aluminum powder, and other ignitable metal powders and sodium dithionite (hydrosulfite).
	Oxidants	1. Potassium chlorate, Sodium chlorate, Ammonium chlorate, and other chlorates.
		2. Potassium perchlorate, Sodium perchlorate, Ammonia perchlorate, and other perchlorates.
		3. Potassium peroxide, Sodium peroxide, Barium peroxide, and other inorganic peroxides.
		4. Potassium nitrate, Sodium nitrate, Ammonia nitrate, and other nitrates.
		5. Sodium chlorite and other chlorites.
		6. Calcium hypochlorite and other hypochlorites.
	Ignitable Substances	<ul style="list-style-type: none"> <li>Ethyl ether, Gasoline, Acetaldehyde, Propylene chloride, Carbon disulfide, and flammable substances with a flash point below minus 30°C.</li> </ul>
		<ul style="list-style-type: none"> <li>Normal hexane, Ethylene oxide, Acetone, Benzene, Methyl ethyl ketone, and flammable substances with a flash point between minus 30°C and 0°C.</li> </ul>
		<ul style="list-style-type: none"> <li>Methanol, Ethanol, Xylene, Pentyl acetate (amyl acetate), and inflammable substance with a flash point between 0°C and 30°C.</li> </ul>
<ul style="list-style-type: none"> <li>Kerosene, Light oil, Turpentine oil, Isoamyl alcohol, Acetic acid, and flammable substances with a flash point between 30°C and 65°C</li> </ul>		
Combustible Gases	Hydrogen, Acetylene, Ethylene, Methane, Ethane, Propane, Butane, and other gases that are flammable under 1 atmospheric pressure at 15°C.	

(Quoted from "Addendum Table1 of Code of Work Safety and Hygiene Standard")

## Explanation of Character on the display

The oven has the controller with the 4-digit LED display. The meaning of Character on the display is as follows:

Capital	Character	Meaning of Abbreviation	Meaning of Character on the display
A	Accn	accumulation	Integrated time
B	bEEP	beep	Alarm sound setting mode
D	dELP	delete program	Deleting a program
	dISP	display	Sub display switching mode
E	End	end	Setting mode for program end
	Er.	error ##	Error code ##
F	F. wt	f. wt (Forced wait)	Forced wait state after the power restoration
H	Hold	hold	Hold function mode
	hr.nn	hr. mn (hour. minute)	Setting of time (hour, minute)
L	Lock	lock	Panel locking mode
M	nn.dY	mn. dy (month. day)	Setting of the date (month and day)
O	off	off	Make a function inactive
	on	on	Make a function active
P	Pr. ##	program ##	Program number
	Prog	program	Program mode
	Pr.SG	program, segment	Ongoing program and ongoing segment
R	r.cnt	repeat count	Repeat frequency setting mode
	rEAL	real (real time)	The hour
	rEP	repeat	Repeat command mode
	rEst	rest time	Rest for remaining time
	rL.##	ramp level	Ramp level of Segment ## (Desired set temperature)
	r.StR	repeat start	Repeat start segment setting mode
	r.t.##	ramp time	Ramp time of Segment ## (Time required to reach the ramp level)
	r.t.in	r. tim (real time)	the hour
S	SG.##	segment	Segment number
	St.##	soak time	Soak time of Segment ## (Holding time of the ramp level)
	StEP	step	Not in Ramp Operation
T	tEnP	temp	Temperature mode
	t.inE	time	Time mode
W	WA it	wait	Wait function (Keep the operation until the desired temperature is achieved)
	Wt.##	wait ##	Wait function of Segment ##
Y	YEAr	year	the Christian era

## Behavior after Power Restoration

When having a blackout during operation, the controller resumes the following operations after the power restoration.

### When having a blackout during the program operation

The controller automatically resume the program operation where it left at the power shutdown. In case that the temperature inside the chamber is outside the specified temperature range based on the setpoint temperature, the controller goes to the FORECED WAIT STATE until the temperature inside the chamber comes back to the specified temperature range. When selecting the indication of the remaining time by pushing the Display key in this condition, the sub display shows

The sub display shows the text 'F. 00' in a digital font, enclosed in a rectangular border.

The timer built-in the controller does not count a period of having a blackout as running time.

### When having a blackout during the Auto-Stop operation

The controller automatically resume the Auto-Stop operation where it left at the power shutdown. In case that the temperature inside the chamber is outside the specified temperature range based on the setpoint temperature after the power restoration, the controller goes to the FORECED WAIT STATE until the temperature inside the chamber comes back to the specified temperature range. When selecting the indication of the remaining time by pushing the Display key in this condition, the sub display shows

The sub display shows the text 'F. 00' in a digital font, enclosed in a rectangular border.

(Forced Wait)

In case that the operation stop time is set in a period of time, the timer built in the controller does not count a period of a blackout as running time. On the contrary, in case that the operation stop time is set in hours, the timer built in the controller counts a period of a blackout as running time.

When the operation stop time reaches during a blackout, the controller stops running just after the power restoration.

### When having a blackout while the operation is in standby condition

In case that the operation start time is set in a period of time, the timer built in the controller does not count a period of a blackout as standby time. On the contrary, in case that the operation start time is set in hours, the timer built in the controller counts a period of a blackout as standby time.

When the operation start time reaches during a blackout, the controller starts running just after the power restoration.

### When having a blackout during the Fixed temperature operation and a soak period of the Auto-Start operation

The controller resumes running toward to the preset temperature after the power restoration.

# Flowchart of Operational Procedures

## Run "MENU"

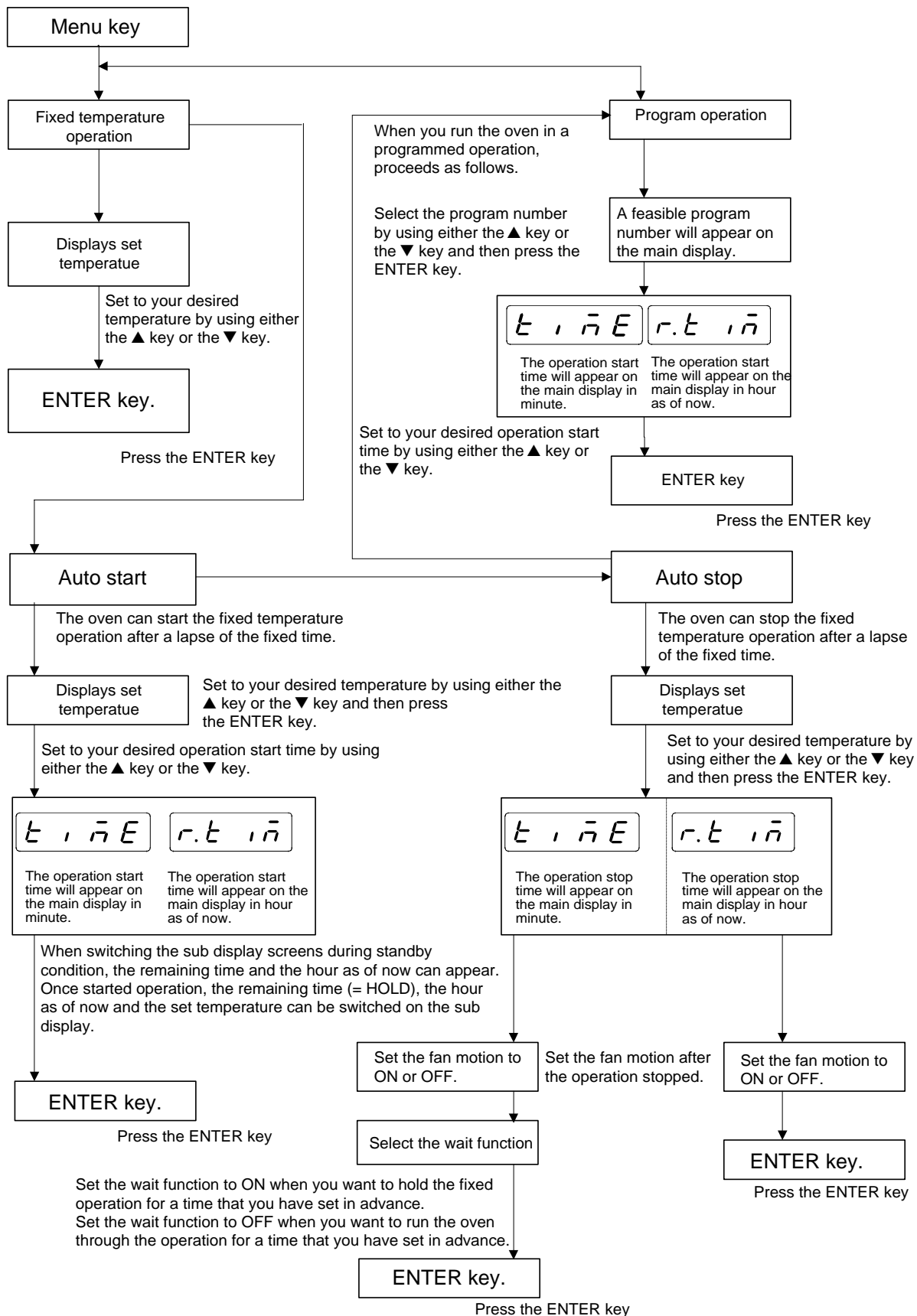

# Program "MODE"

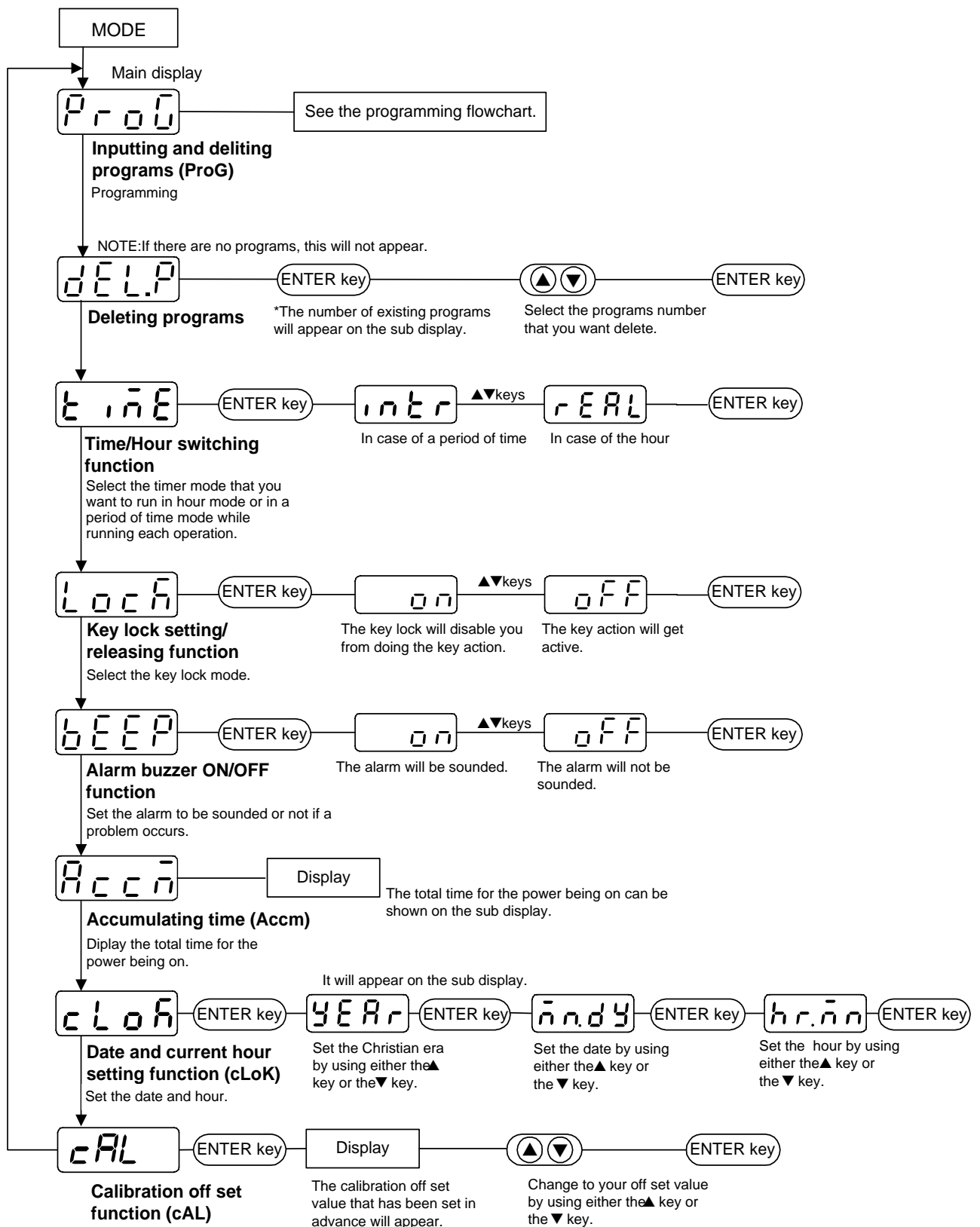



# Flowchart for programming

## Segment configuration

: Segments are made up of the following items, and must be input in this order.

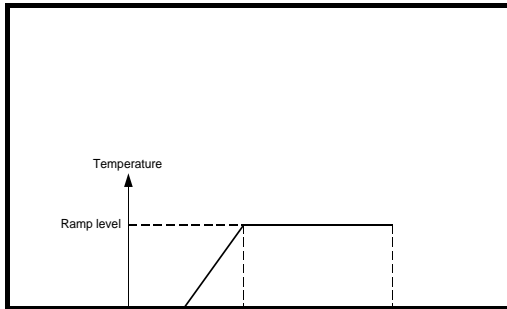

Ramp time

Rising time

Ramp level

Target temperature

Soak time

Time held at ramp level

Wait function

Selects whether to give priority to soak time (OFF), or to hold process time at ramp level (ON).

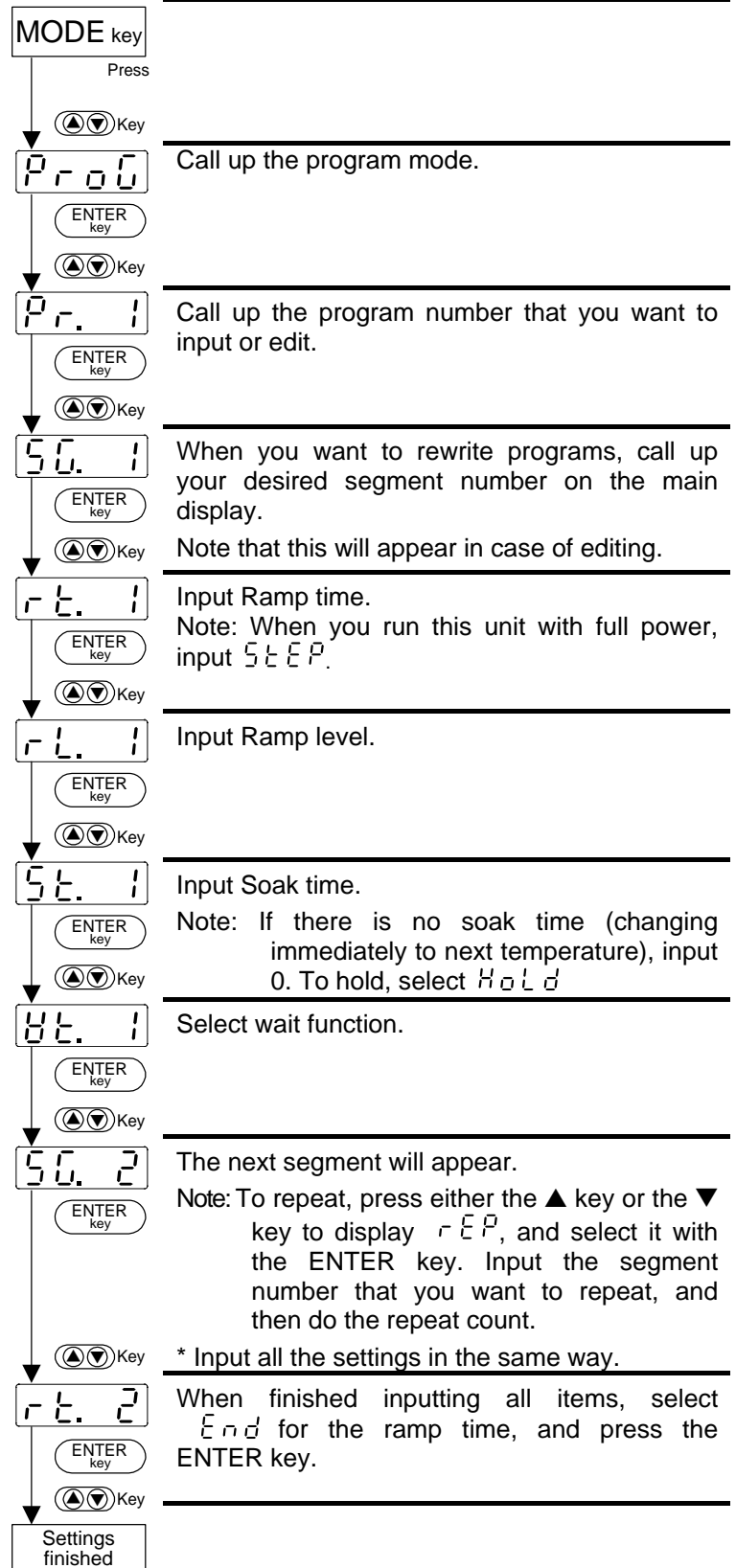

## REFERENCE DATA

The data below should be used for reference only, these values are not guaranteed actual results may vary.

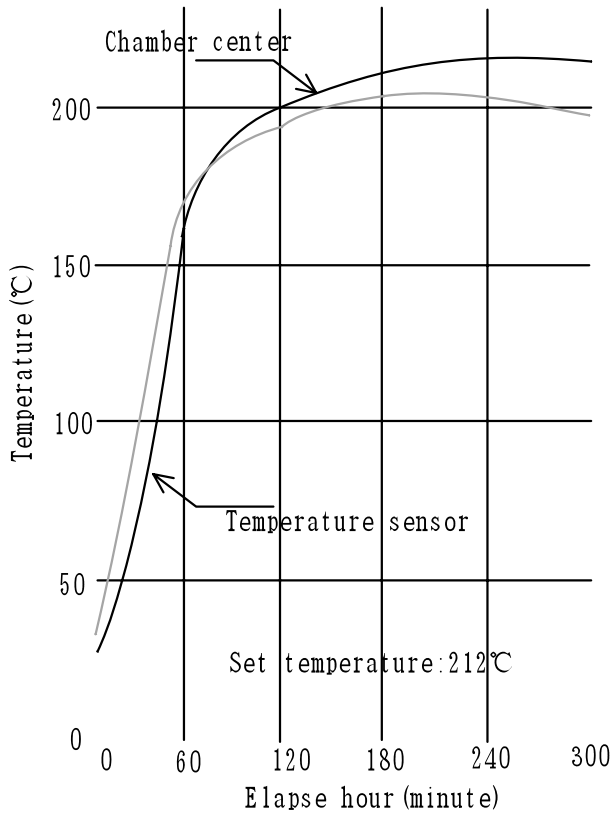

Temperature rising character of Model DP-43. (Vacuum state: below 1 Torr (0.1kPa))

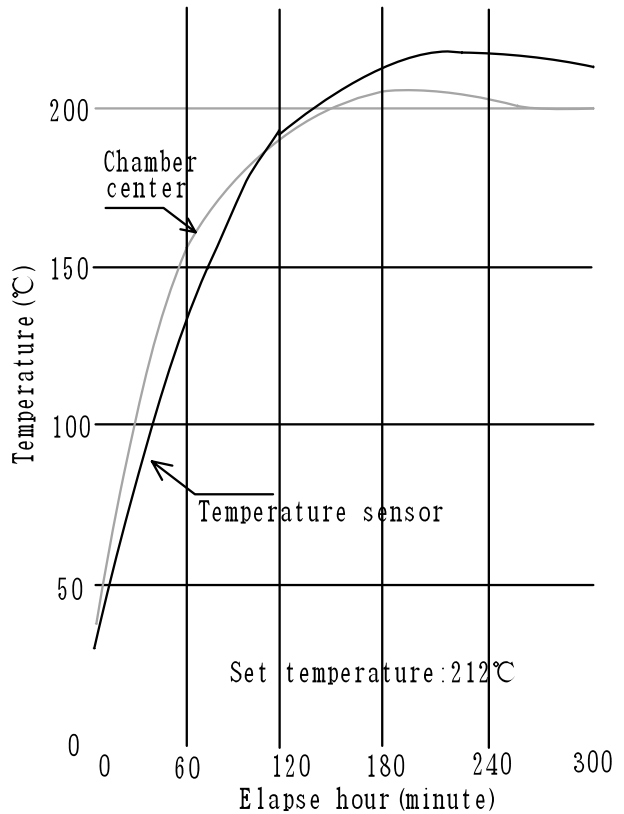

Temperature rising character of Model DP-63. (Vacuum state: below 1 Torr (0.1kPa))

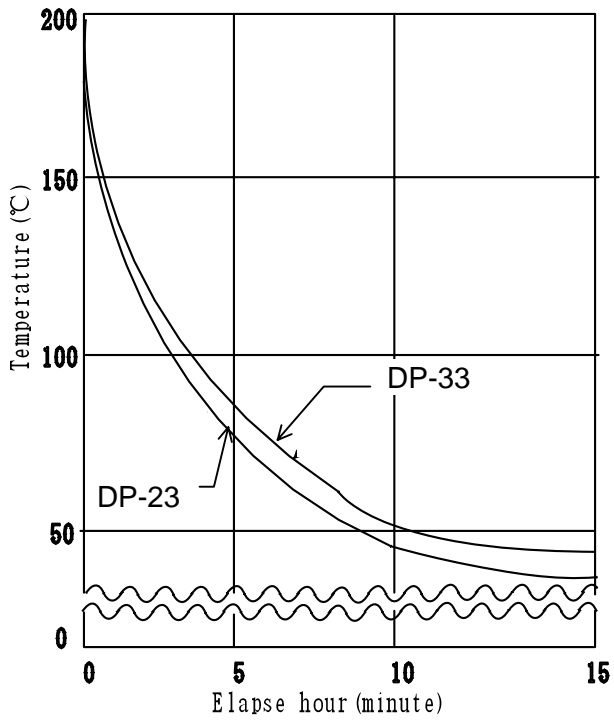

Temperature rising character of Model DP-23/33;(chamber center). (Vacuum state: below 1 Torr (0.1kPa))

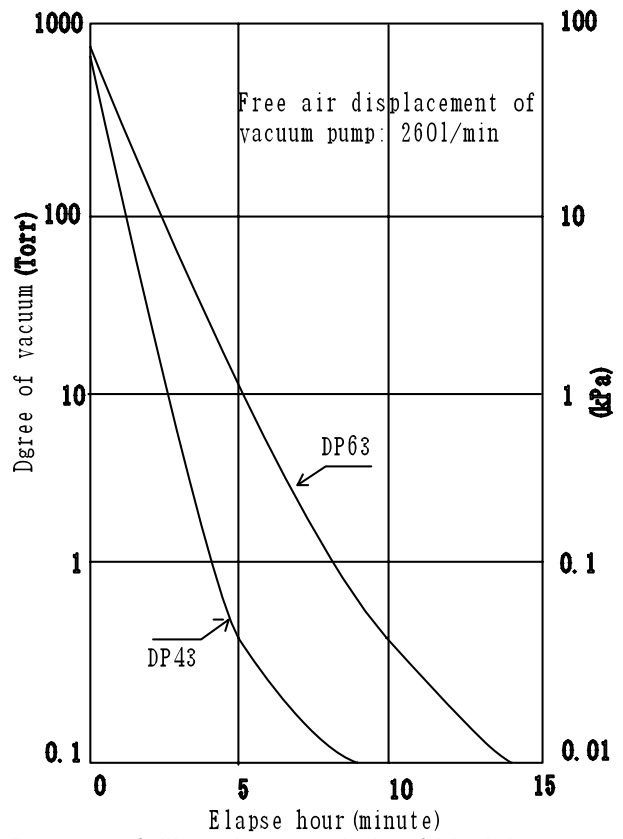

Pressure falling characteristic of Models DP-43/63.

## **Responsibility**

Please follow the instructions in this document when using this unit. Yamato Scientific has no responsibility for the accidents or breakdown of device if it is used with a failure to comply. Never conduct what this document forbids. Unexpected accidents or breakdown may result in.

## **Note**

- ◆ The contents of this document may be changed in future without notice.
- ◆ Any books with missing pages or disorderly binding may be replaced.

Instruction Manual for

**VACUUM DRYING OVENS**

**Model DP23/33/43/63**

First Edition Feb. 16, 2006

---

**Yamato Scientific America, Inc.**

925 Santa Clara, Walsh Avenue,  
TCA 95050, U.S.A

<http://www.yamato-usa.com>