

LIFTING TOOLS FOR NURSERY WORKERS

Problem:

Lifting and carrying plant containers by hand can cause injuries to hands and back.



- Worker must stoop, grip and lift repeatedly.
- Forward stooping can contribute to lower-back injury.
- Finger-pinch gripping can lead to tendinitis in hands.

One Solution:

Use handles to pick up and carry containers.



- Tool handle allows a full-hand "power grip" rather than a pinch grip.
- Decreases forward bending angle and amount of time spent in stooped posture.
- Reduces lifting strain.
- Can improve worker productivity.

Tips for Use of Tool:

The tool is designed to allow the container to swing back and hang at a comfortable angle. Do not apply excessive wrist torque when setting container down onto a surface. Instead, allow space for a gentle forward swing that is timed with placement of the container on the surface. The back-grip design keeps hands clear of thorns on certain types of plants and allows for a neutral wrist position while carrying a container. It is advisable to use two tools and carry two plants, to balance the load on the body. Avoid carrying containers heavier than about 22 pounds in each hand; this would exceed guidelines for safe lifting.

**University of California Agricultural Ergonomics Research Center
TIP SHEET 001 Nursery Lifting Tool**

HOW DOES THE LIFTING TOOL WORK?

The tool has three parts: a) the hand-grip, b) the container coupling, and c) the 16-inch extension. It is made of aluminum and steel and has proven to work best with 5-gallon containers that have an external lip. From a standing position the worker slides the coupling point under the container's lip and lifts.

HOW MUCH DIFFERENCE DOES USE OF THE TOOL MAKE?

The tool shown here was designed for use in outdoor nurseries specializing in ornamental and bedding plants. At California nurseries where it was tested, it reduced workers' forward bending angle by as much as 47%. The time spent working at a forward bent angle of more than 20 degrees was reduced by nearly half. Hand gripping effort was reduced by more than half. Lifting strain was reduced by 40%. Workers reported feeling less work-related pain when using them, and those who had the most severe symptoms at the start reported the most improvement.

HOW MUCH WILL IT COST?

Materials should cost about \$15 each plus the cost of fabrication, whether done in-house or jobbed out.

HOW DOES TOOL USE AFFECT PRODUCTIVITY?

Use of the handle resulted in the same or slightly improved productivity for ground-to-ground container spacing, its recommended use.

HOW TO MAKE LIFTING TOOLS

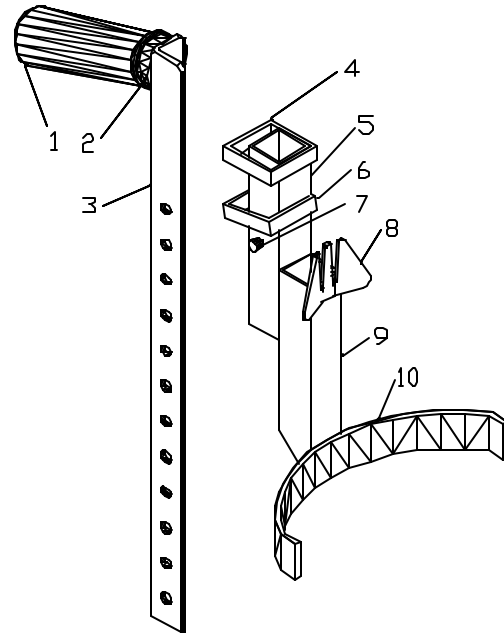

Materials List & Construction Information:

- | # | Description |
|----|--|
| 1 | Rubber grip; tapered from about 1.1875" to 1.4375" OD"; to fit 1" OD tube; typically available in industrial supply catalogs. |
| 2 | 1" OD x 0.065" wall aluminum tube; cut at 21°; 4.75" on long side; welded at 69° angle to Part 3. |
| 3 | 1" x 1" x 0.125" x 16"-long aluminum angle; holes drilled on 1" centers and 0.5" from edge measured on 1"-wide side. |
| 4 | 1.5" x 1.5" x 0.094" x 0.375"-long steel sq. tube; welded along top joint. |
| 5 | 1" x 1" x 0.065" x 5"-long steel sq. tube; 0.25" hole drilled 2.5" from end & 0.375" from edge; welded to Part 9 w/ 2" overlap. |
| 6 | 1.5" x 1.5" x 0.094" x 0.375"-long steel sq. tube; remains loose on tube. |
| 7 | 0.25" D x 1"-long steel round; inserted into Part 5 and welded flush on the non-visible side in pictorial above. |
| 8 | 1.5" x 0.125" steel flat bar cut at about 45° with approximate top and bottom lengths of 2.5" and 1.0", respectively; notched generally as shown in pictorial above (notches are for container lips that have reinforcement ribs that may interfere with the coupling of the "point" and the container); ends bent slightly forward after welding; welded to Part 9 with 0.5" overlap. |
| 9 | 1" x 1" x 0.065" steel sq. tube; cut at 45°; 4.5" on long side. |
| 10 | 1" x 0.125" x 9.5" long steel flat bar; 0.5" end-bends pointing forward; approx. 7.25" overall width after rolling; welded at bottom of Part 9. |

Note: Steel may be substituted for aluminum for cost or fabrication reasons, but steel will increase the tool's weight from its current 1.75 pounds.