

CAD DRAWINGS

REVISION HISTORY

REV	DESCRIPTION	DATE	APPROVED

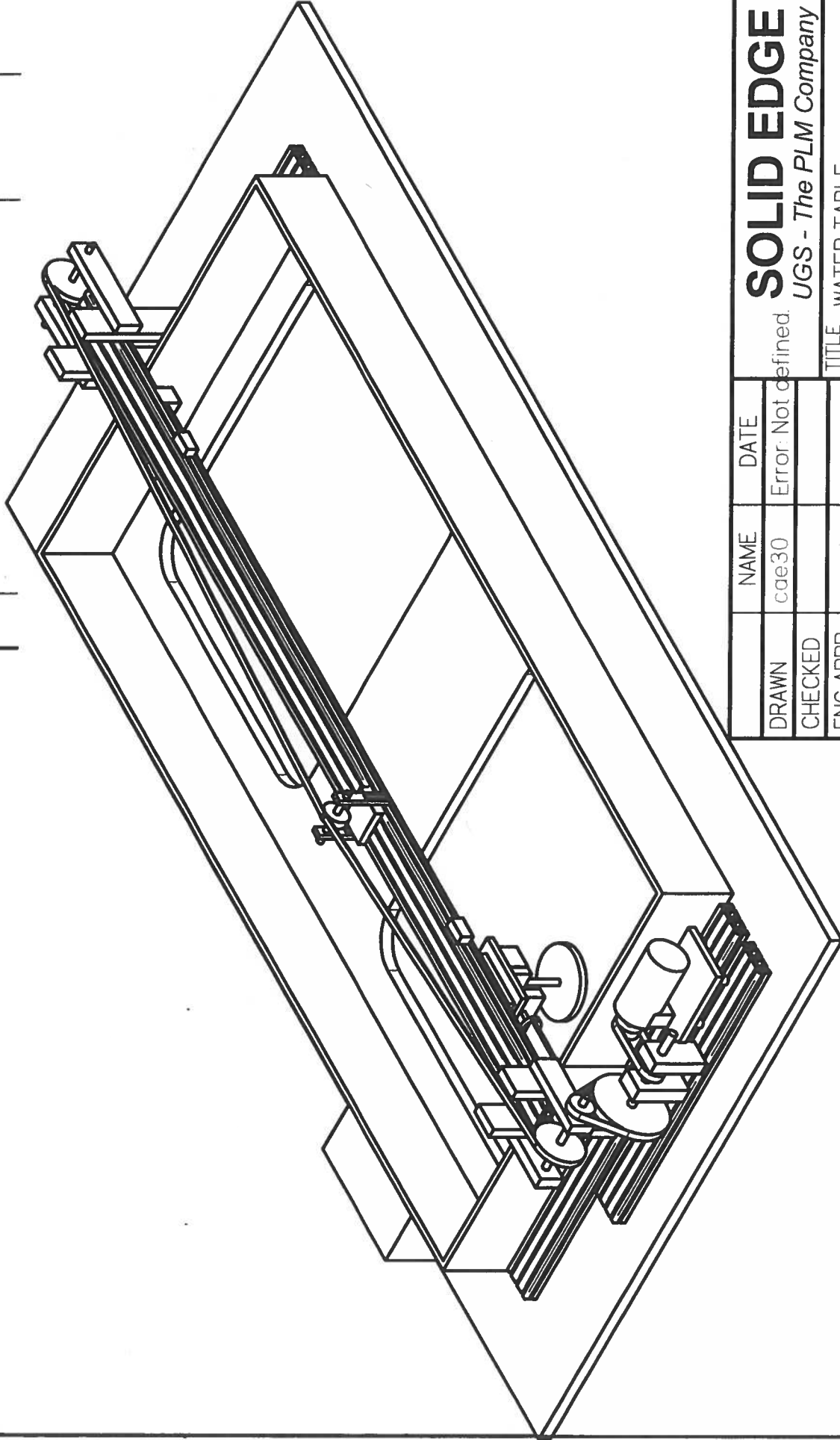

SOLID EDGE
UGS - The PLM Company

NAME	DATE
cae30	Error: Not defined.
CHECKED	
ENG APPR	
MGR APPR	

TITLE WATER TABLE
 SIZE DWG NO A
 FILE NAME Draft1
 SCALE 1:10 WEIGHT: SHEET 1 OF 1

UNLESS OTHERWISE SPECIFIED
 DIMENSIONS ARE IN INCHES
 ANGLES ±XX°
 2 PL ±XXX 3 PL ±X.XXX

CAD DRAWINGS: CARRIAGE COMPONENTS

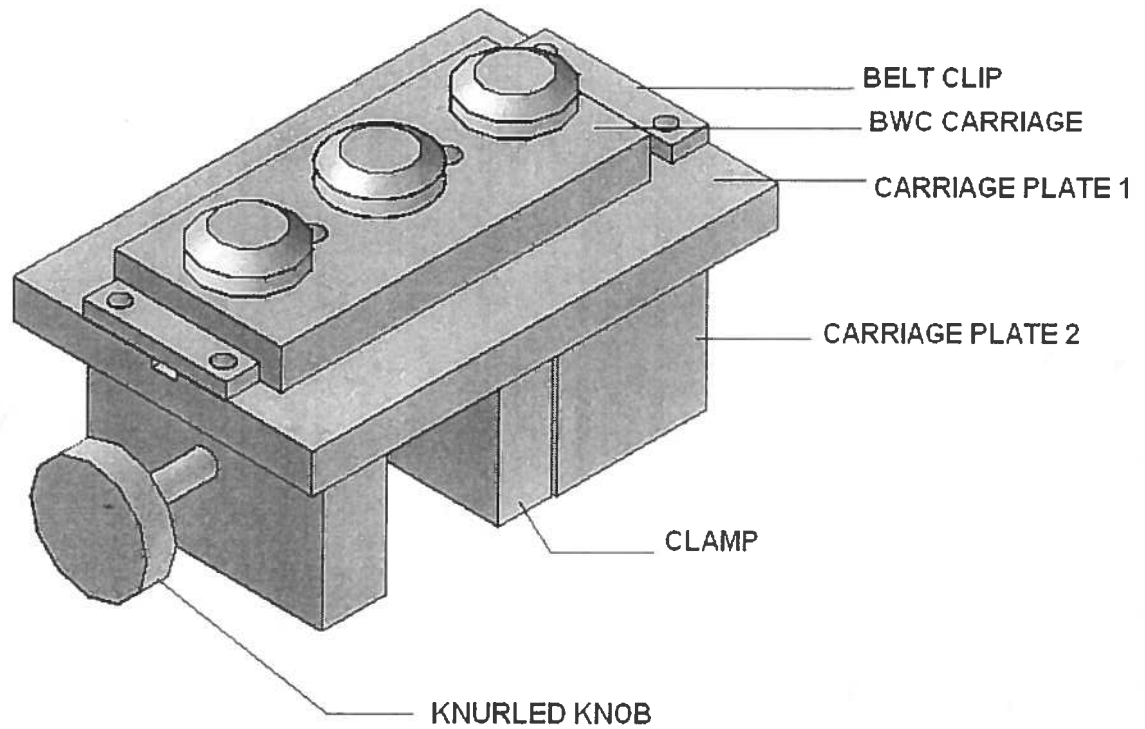

REVISION HISTORY

REV	DESCRIPTION	DATE	APPROVED
	BWC CARRIAGE		

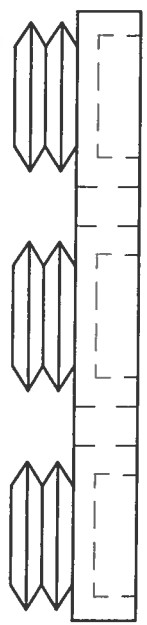
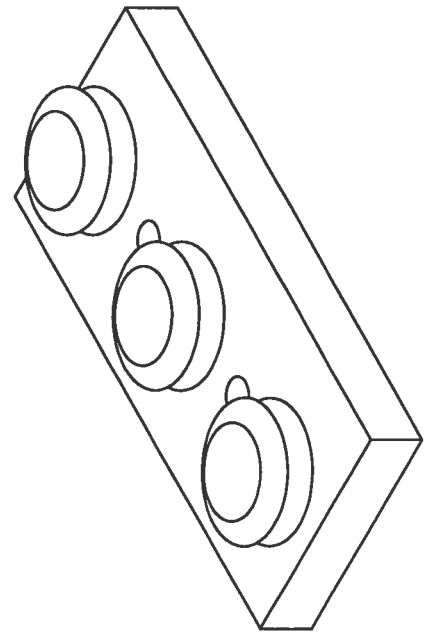

NAME	DATE
DRAWN	03/16/06
CHECKED	
ENG APPR	
MGR APPR	

SOLID EDGE	
UGS - The PLM Company	
TITLE BWC CARRIAGE	
SIZE	DWG NO
A3	
REV	

UNLESS OTHERWISE SPECIFIED
 DIMENSIONS ARE IN INCHES
 ANGLES ±XX°
 2 PL ±XXX 3 PL ±XXXX

FILE #4411 BWC CARRIAGE.DWG	SCALE 1:1	WEIGHT	SHEET 1 OF 1
-----------------------------	-----------	--------	--------------

REVISION HISTORY

REV	DESCRIPTION	DATE	APPROVED
	CARRIAGE - PLATE 1		

NOTE
 A. 1/4" THROUGH HOLE X 4
 B. M8
 C. 1/4" THROUGH HOLE X 4

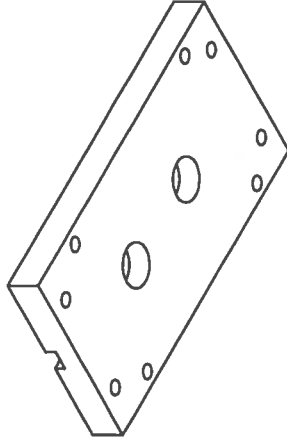
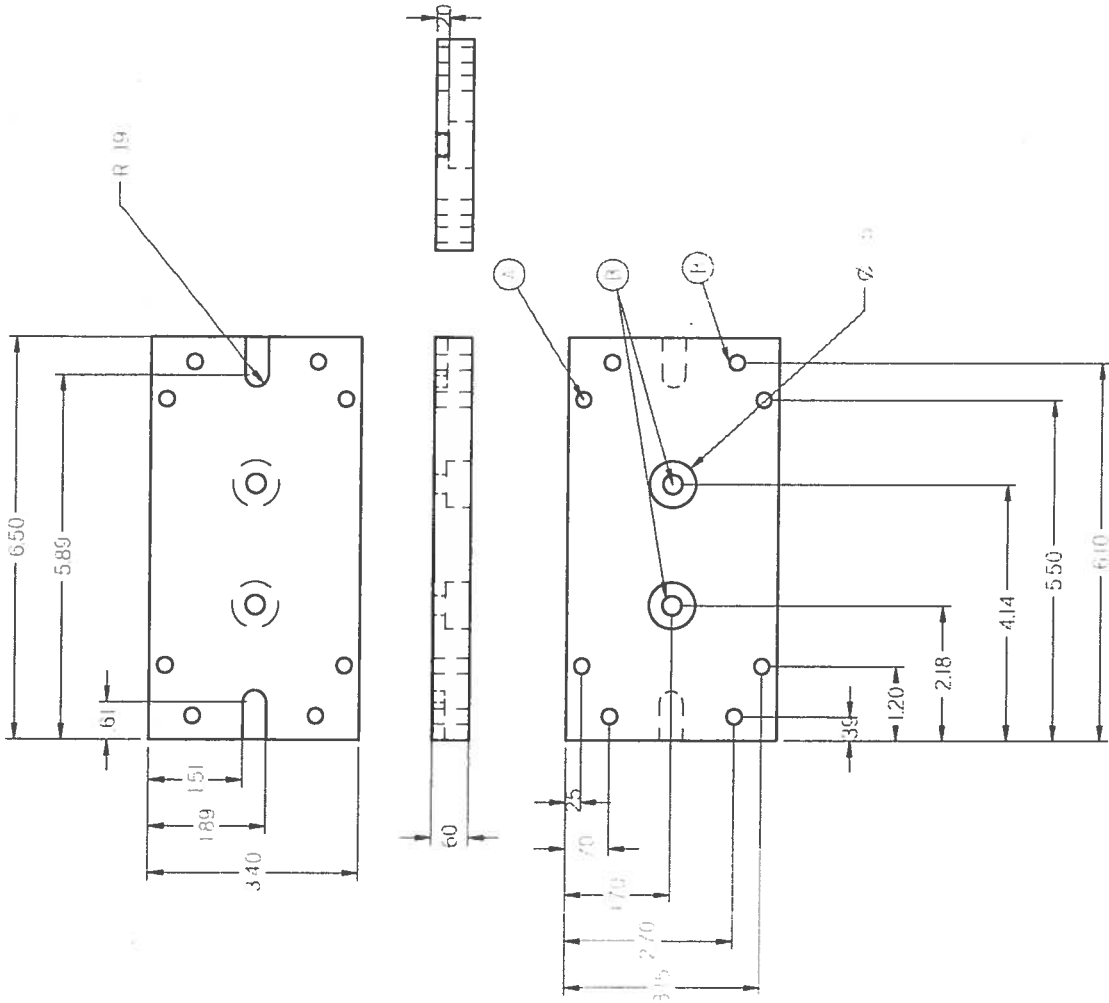

NAME	DATE
DRAWN	
CHECKED	
ENG APPR	
MGR APPR	

SOLID EDGE	
UGS - The PLM Company	
TITLE CARRIAGE - PLATE 1	
SIZE A3	DWG NO
UNLESS OTHERWISE SPECIFIED DIMENSIONS ARE IN INCHES ANGLES ±XX° 2 PL ±XXX 3 PL ±XXXX	
SCALE 12	WEIGHT
SHEET 1 OF 1	

REVISION HISTORY

REV	DESCRIPTION	DATE	APPROVED
	CARRIAGE - PLATE 2		

NOTE
 A. 1/4" THROUGH HOLE X 4
 B. 3/8"-16 THREADED THROUGH

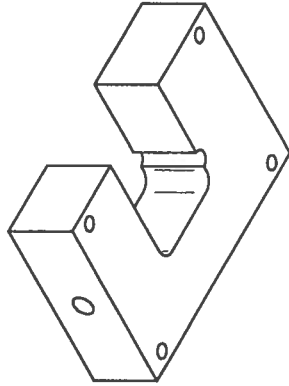
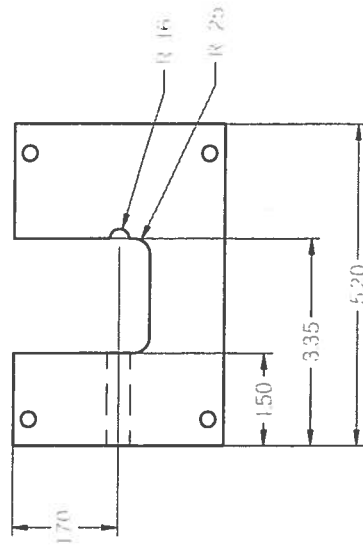
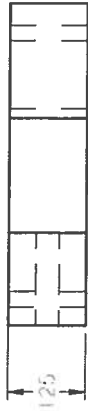
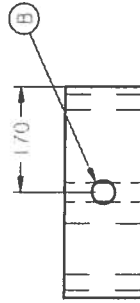
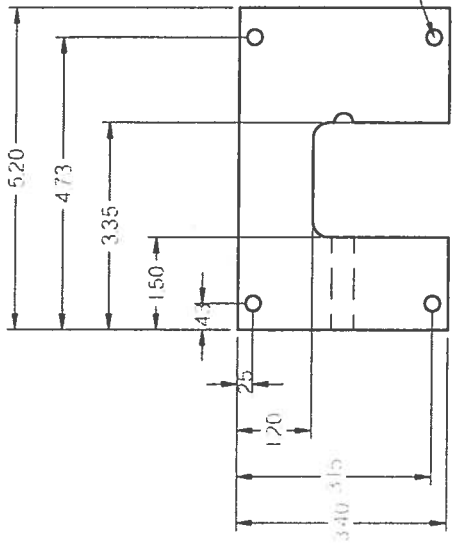

NAME		DATE
DRAWN	Footprint	03/11/2016
CHECKED		
ENG APPR		
MBR APPR		

UNLESS OTHERWISE SPECIFIED DIMENSIONS ARE IN INCHES ANGLES ±XX° 2 PL ±XXX 3 PL ±XXXX		SIZE A3	DWG NO	REV
		FILE \\ASKE_Carriage-Plate2.dwg		

SOLID EDGE	
UGS - The PLM Company	
CARRIAGE - PLATE 2	
SCALE 1:2	WEIGHT
SHEET 1 OF 1	

REVISION HISTORY

REV	DESCRIPTION	DATE	APPROVED
	CLAMP		

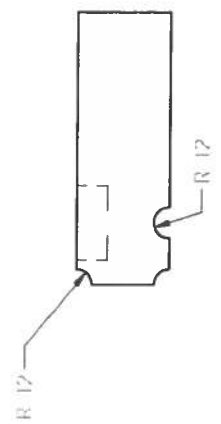
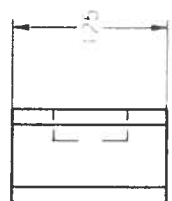
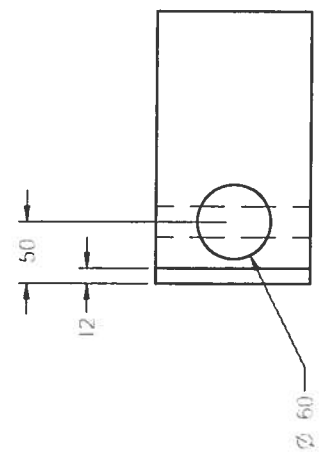
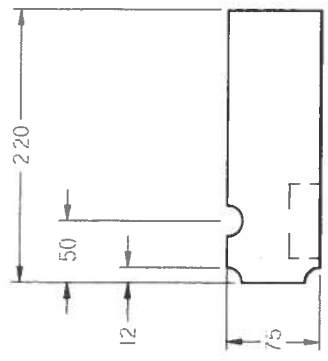
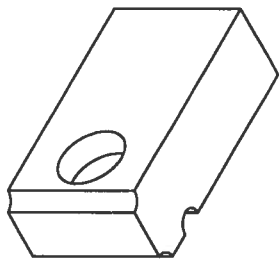

DRAWN		NAME	DATE
CHECKED		Forino	01/15/06
ENG APPR			
MGR APPR			
UNLESS OTHERWISE SPECIFIED DIMENSIONS ARE IN INCHES ANGLES ±XX° 2 PL ±X.XX 3 PL ±X.XXX			
TITLE		CLAMP	
SIZE	DWG NO	REV	
A3			
SCALE		1:1	WEIGHT
SHEET		1 OF 1	

SOLID EDGE
UGS - The PLM Company

REVISION HISTORY

REV	DESCRIPTION	DATE	APPROVED
	BELT CLIP		

NOTE:
A 1/4 THROUGH HOLE X 2

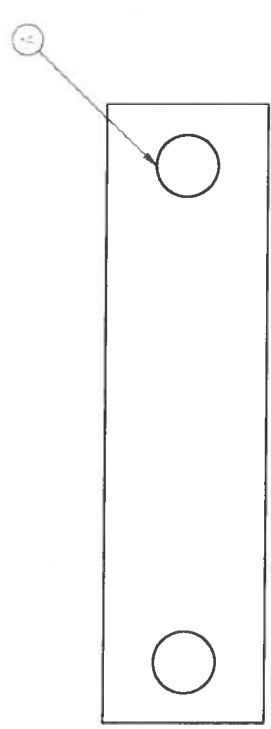
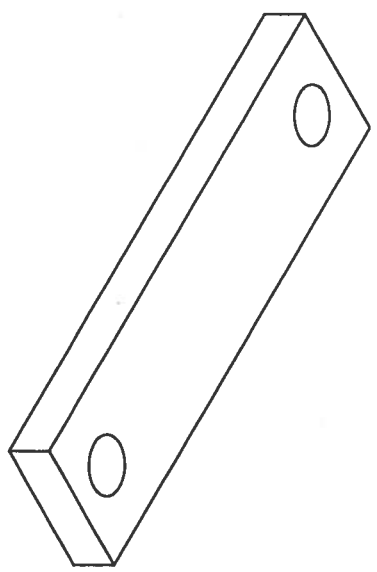
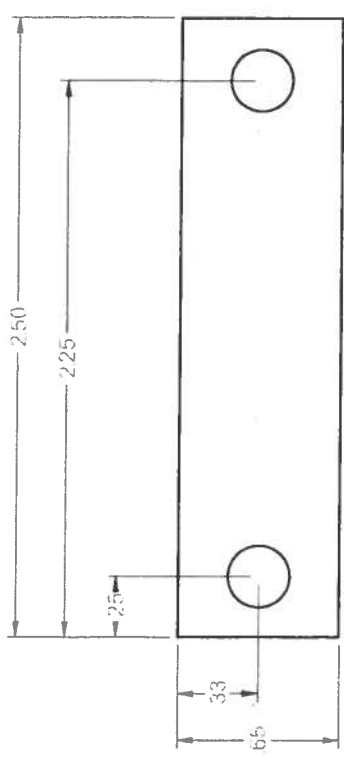

DRAWN		NAME	DATE
CHECKED		Enstrom	03/15/06
ENG APPR			
MGR APPR			
UNLESS OTHERWISE SPECIFIED DIMENSIONS ARE IN INCHES ANGLES ±XX° 2 PL. ±XXX 3 PL. ±XXXX			
TITLE		BELT CLIP	
SIZE	DWG NO	REV	
A3			
FILE NAME: Belt Clip.dwg		SCALE: 1:1	WEIGHT
SHEET 1 OF 1			

SOLID EDGE
UGS - The PLM Company

REVISION HISTORY

REV	DESCRIPTION	DATE	APPROVED
	KNURLED KNOB		

NOTE
 A. KNURLED SURFACE
 B. 3/8-16 SCREW

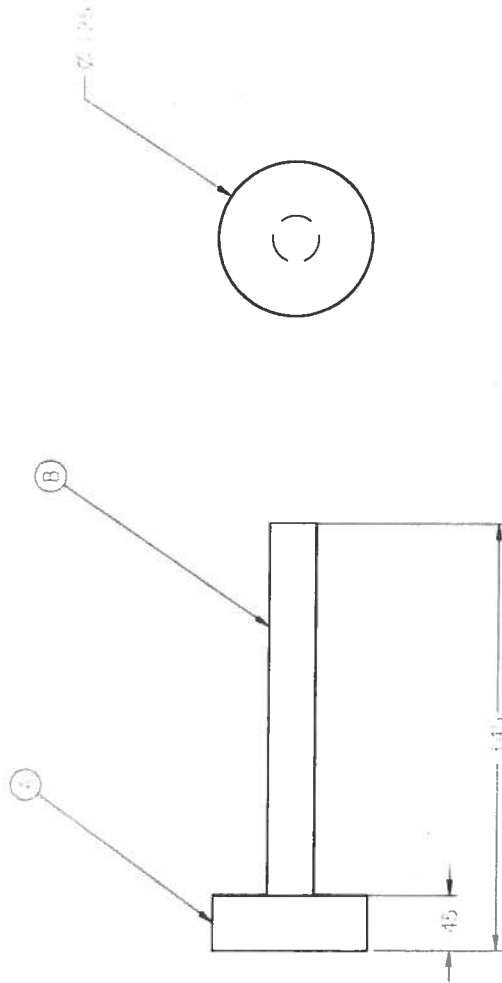
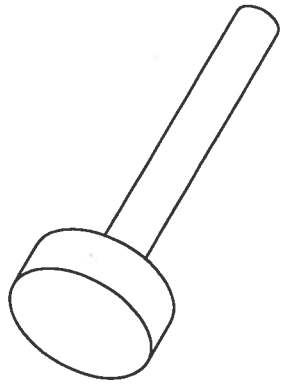

DRAWN		NAME	DATE
CHECKED		Katrina	03/16/06
ENG. APPR.			
MGR. APPR.			
UNLESS OTHERWISE SPECIFIED DIMENSIONS ARE IN INCHES ANGLES ±XX° 2 PL ±.XXX 3 PL ±X.XXX			
SIZE		DWG NO	
A3			
FILE NAME		knob.dwg	
SCALE		1:1	WEIGHT
SHEET		OF 1	

SOLID EDGE
 UGS - The PLM Company

TITLE
 KNURLED KNOB

CAD DRAWINGS:

RAILINGS

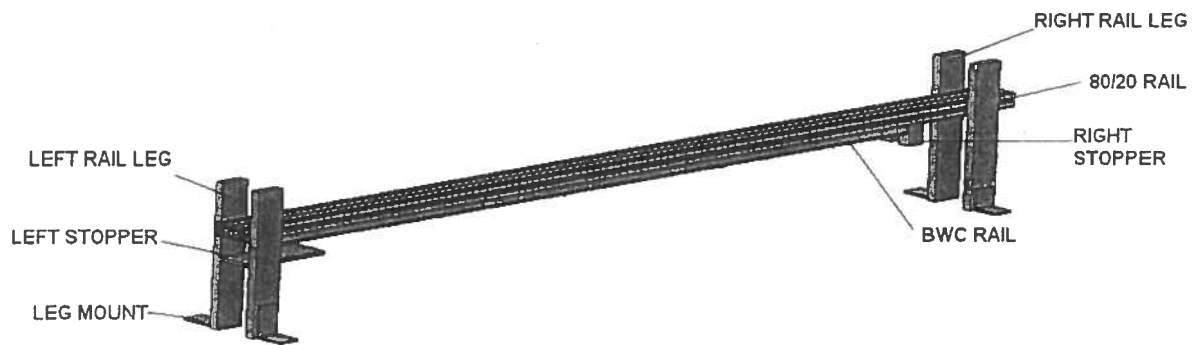

REVISION HISTORY

REV	DESCRIPTION	DATE	APPROVED
	80/20 RAILS		

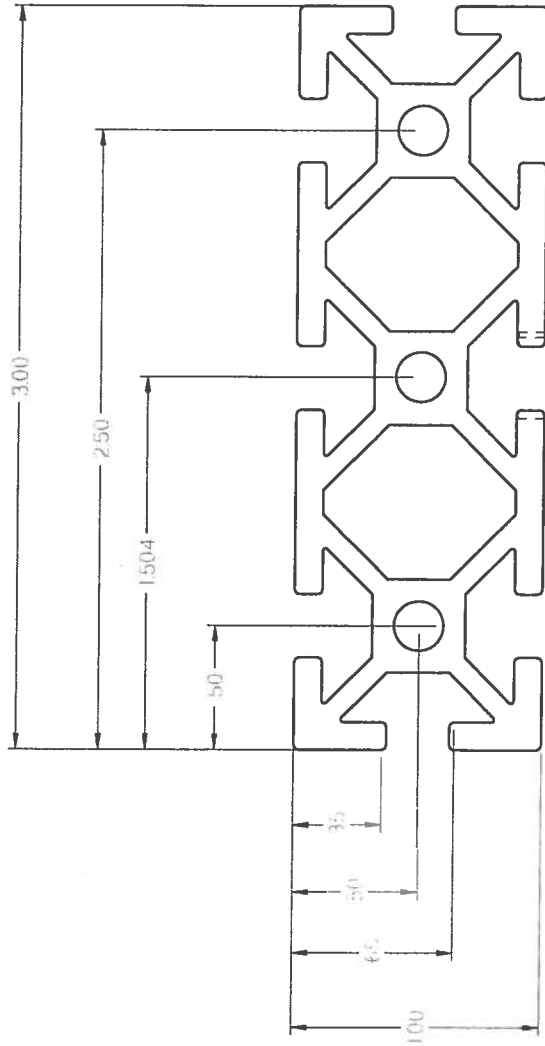

NAME	DATE
DRAWN	07/10/06
CHECKED	
ENG APPR	
MGR APPR	

UNLESS OTHERWISE SPECIFIED
DIMENSIONS ARE IN INCHES
ANGLES ±XX°
2 PL ±XXX 3 PL ±XXXX

SIZE	DWG NO	REV
A3		

FILE NAME: 8020 Rail.dwg

SCALE	WEIGHT
2:1	

SOLID EDGE
UGS - The PLM Company

TITLE
80/20 RAILS

REVISION HISTORY

REV	DESCRIPTION	DATE	APPROVED
	BWC RAILS		

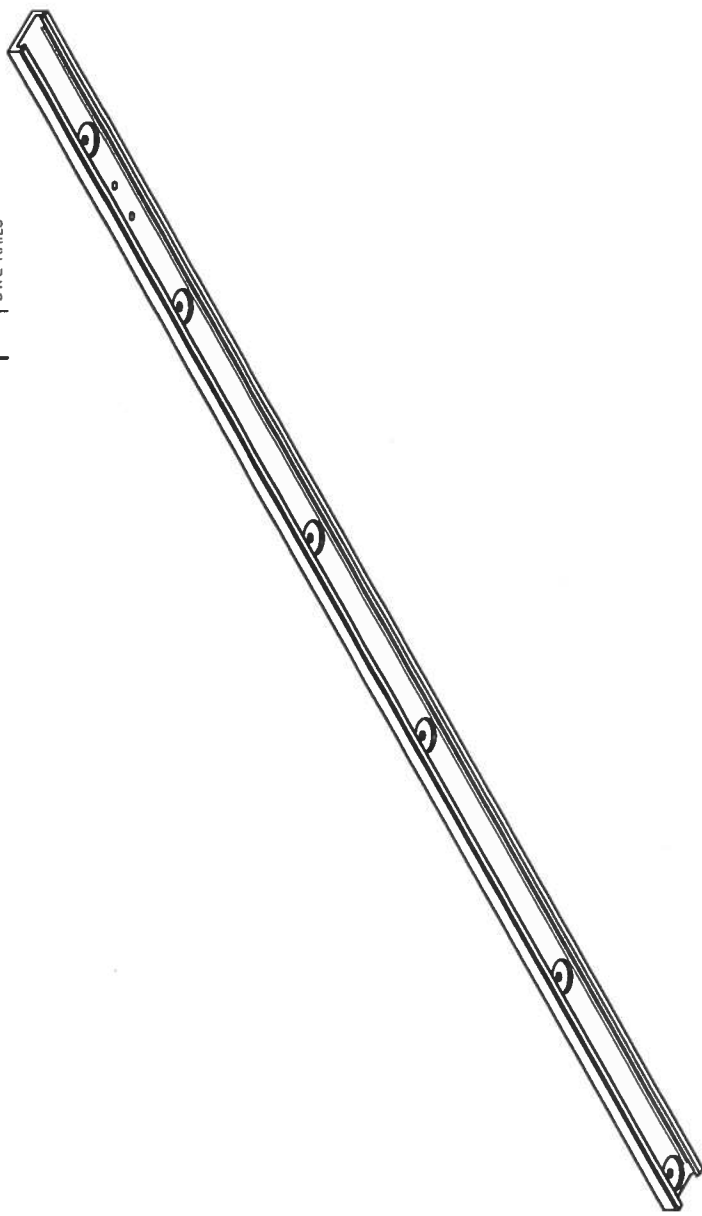

SOLID EDGE		UGS - The PLM Company	
DRAWN		NAME	DATE
CHECKED		K.OTRINA	04/16/06
ENG APPR			
MGR APPR			
UNLESS OTHERWISE SPECIFIED DIMENSIONS ARE IN INCHES ANGLES ±XX°		TITLE	
2 PL ±XXX 3 PL ±XXXX		BWC RAILS	
		SIZE	DWG NO
		A3	
		FILE PATH	REV
		SCALE	WEIGHT
		1:5	
		SHEET 1 OF 1	

REVISION HISTORY

REV	DESCRIPTION	DATE	APPROVED
	BWC RAIL - CROSS SECTION		

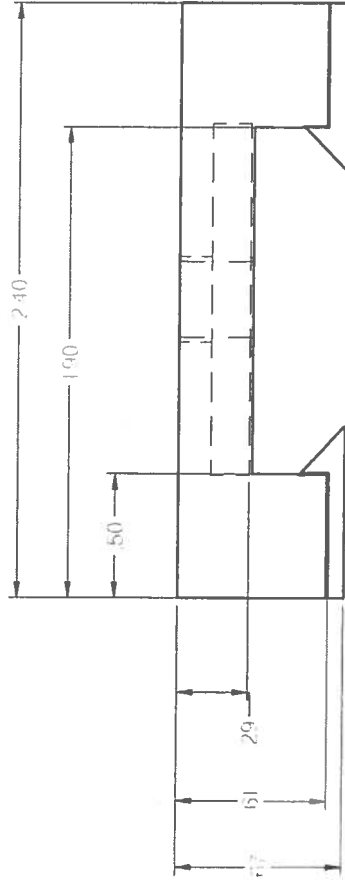

NAME	DATE	REV
Drawn	03/16/06	
Checked		
Eng Appr		
MGR APPR		

UNLESS OTHERWISE SPECIFIED
DIMENSIONS ARE IN INCHES
ANGLES ±XX"
2 PL ±XXX 3 PL ±XXXX

SOLID EDGE	
UGS - The PLM Company	
TITLE	
BWC RAIL - CROSS SECTION	
SIZE	DWG NO
A3	
REV	
FULL NAME BWC RAIL - CROSS SECTION.DWG	
SCALE	WEIGHT
Z1	
SHEET 1 OF 1	

REVISION HISTORY		
REV	DESCRIPTION	DATE
	RIGHT RAIL LEG	
		APPROVED

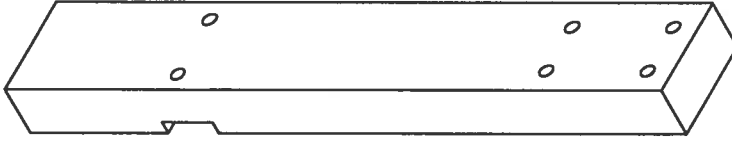

NOTE
A 1/4" THROUGH HOLE X 6

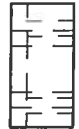
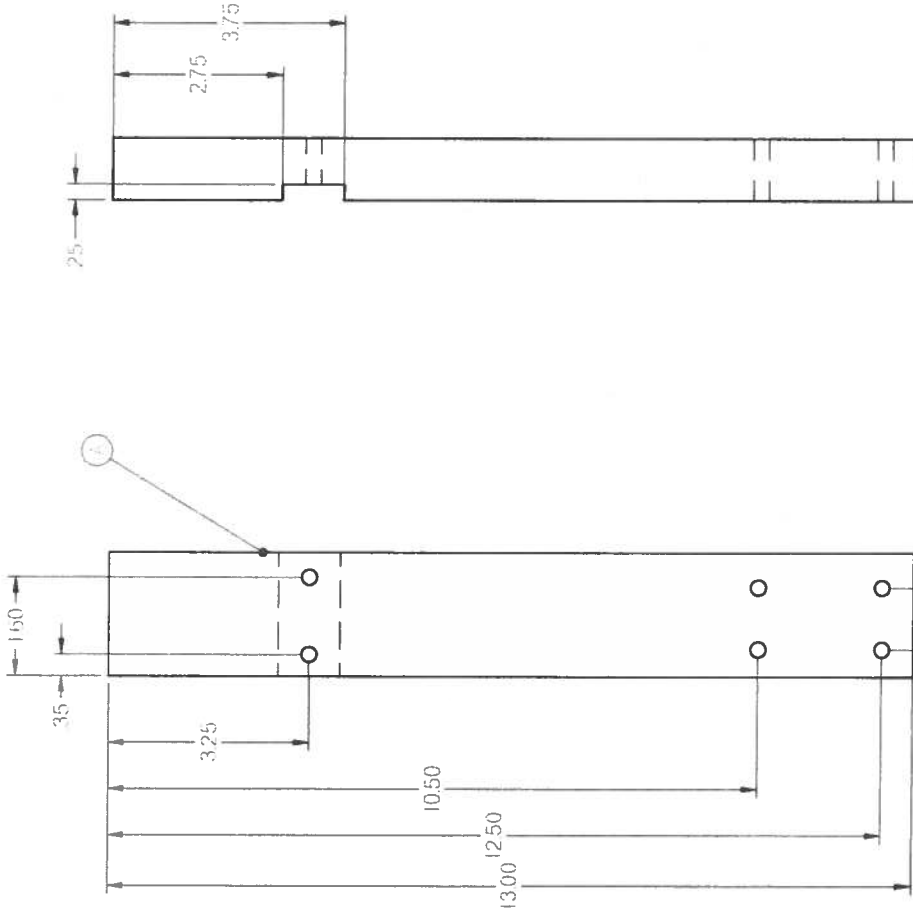
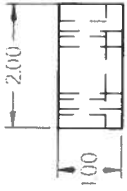

NAME		DATE	
DRAWN	Futima	03/16/06	
CHECKED			
ENG APPR			
MGR APPR			
UNLESS OTHERWISE SPECIFIED DIMENSIONS ARE IN INCHES ANGLES ±XX°			
2 PL ±XXX 3 PL ±XXXX			
TITLE		SIZE	DWG NO
RIGHT RAIL LEG		A3	
FILE NAME: Right Rail Leg.dwg		REV	
SCALE 1:1	WEIGHT	SHEET 1 OF 1	

REVISION HISTORY		
REV	DESCRIPTION	DATE
	LEFT RAIL LEG	
		APPROVED

NOTE: ALL HOLES ARE 1/4" THROUGH

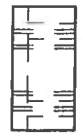
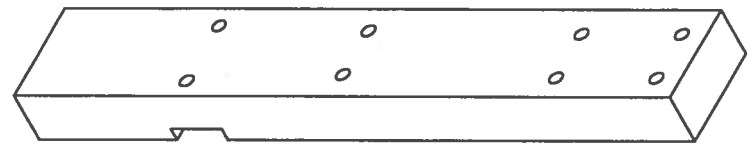
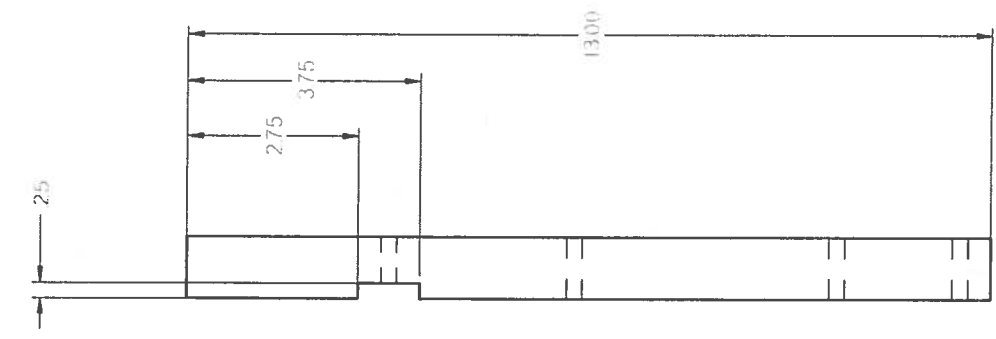
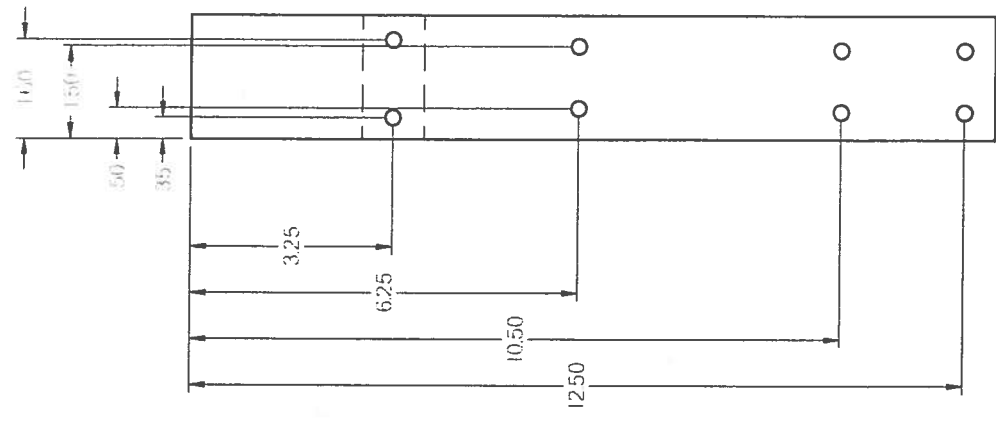
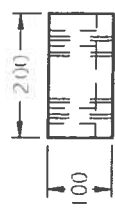

SOLID EDGE		NAME	DATE
UGS - The PLM Company		Katrina	03/16/06
LEFT RAIL LEG		CHECKED	
		ENG APPR	
		MGR APPR	
UNLESS OTHERWISE SPECIFIED DIMENSIONS ARE IN INCHES ANGLES ±XX° 2 PL ±XXX 3 PL ±XXXX		SIZE	DWG NO
		A3	
		FILE NAME	Left Rail Leg.dft
		SCALE	1:2
		WEIGHT	
		SHEET NO	
		REV	

NOTE ALL HOLES ARE 1/4" THROUGH

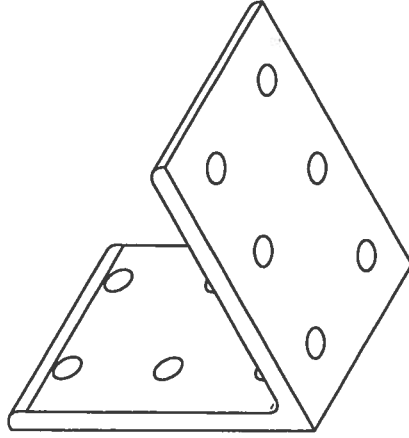
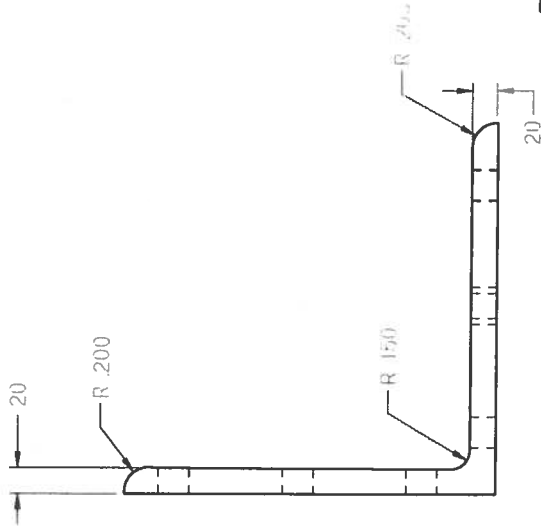
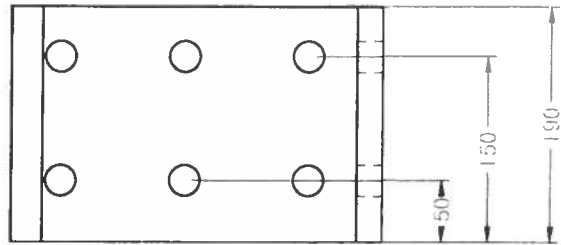
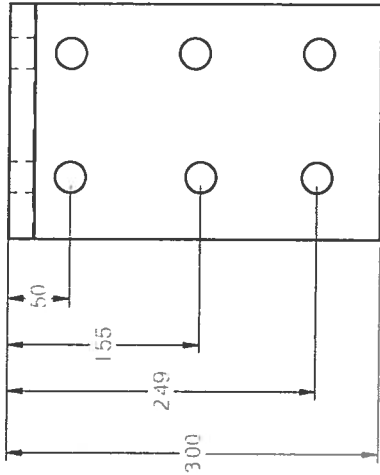

REVISION HISTORY		
REV	DESCRIPTION	DATE
	RAIL LEG MOUNTS	
		APPROVED

DRAWN		NAME	DATE
K. J. J. J.		K. J. J. J.	03/16/06
CHECKED			
ENG APPR			
MGR APPR			
UNLESS OTHERWISE SPECIFIED DIMENSIONS ARE IN INCHES ANGLES ±XX°			
2 PL ±XXX 3 PL ±XXXX			
TITLE		RAIL LEG MOUNTS	
SIZE	DWG NO	REV	
A3			
FILE NAME	SCALE	WEIGHT	
e:\Mounts\11	SCALE 1:1		11.01

SOLID EDGE
UGS - The PLM Company

NOTE: ALL HOLES ARE 1/4" THROUGH

∅ 250

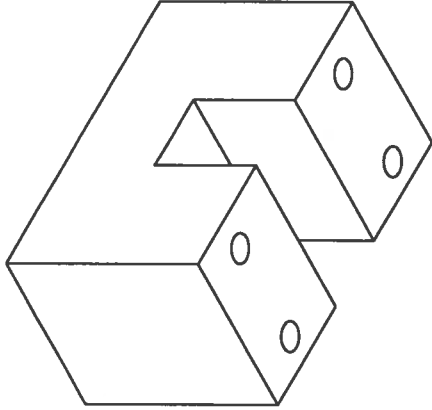
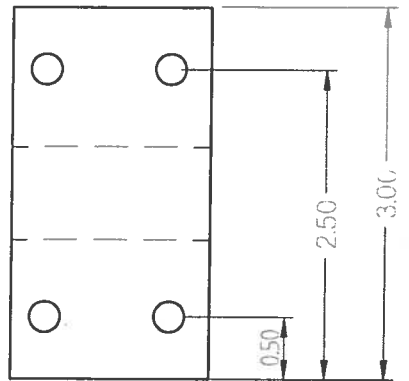
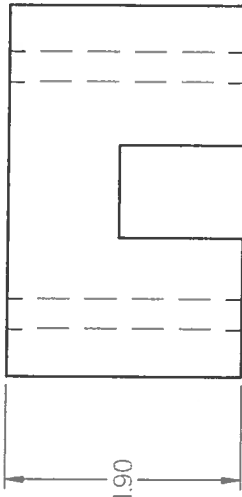
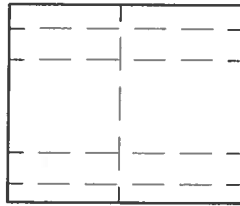
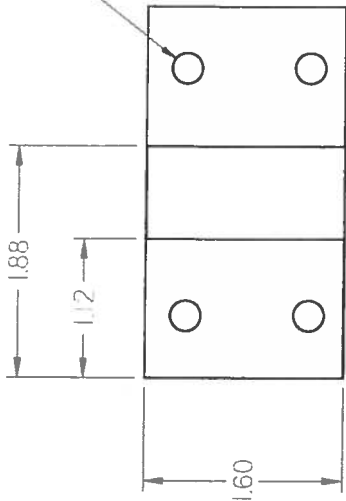

REVISION HISTORY		
REV	DESCRIPTION	DATE
	RIGHT STOPPER	

DRAWN		NAME	DATE
CHECKED		Katrina	03/15/06
ENG APPR			
MGR APPR			
UNLESS OTHERWISE SPECIFIED DIMENSIONS ARE IN INCHES ANGLES ±XX° 2 PL ±XXX 3 PL ±XXXX			
TITLE		RIGHT STOPPER	
SIZE		DWG NO	
A3			
FILE NAME		Right Stopper.dwg	
SCALE		1:1	
WEIGHT		SHEET 1 OF 1	

SOLID EDGE
UGS - The PLM Company

REVISION HISTORY	
REV	DESCRIPTION
	LEFT STOPPER

NOTE
ALL HOLES ARE 1/4" THROUGH

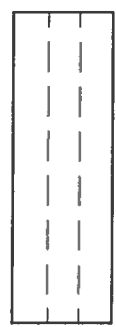
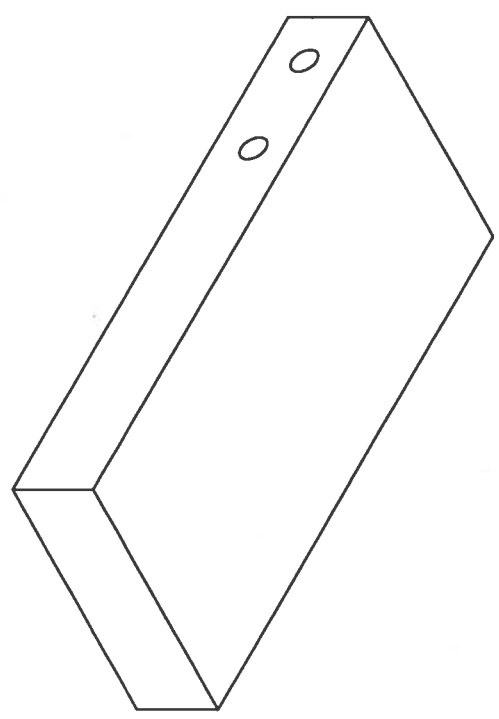
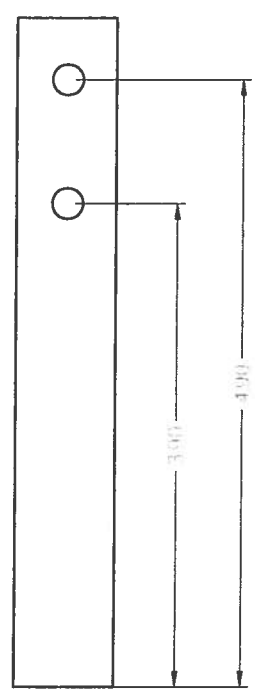
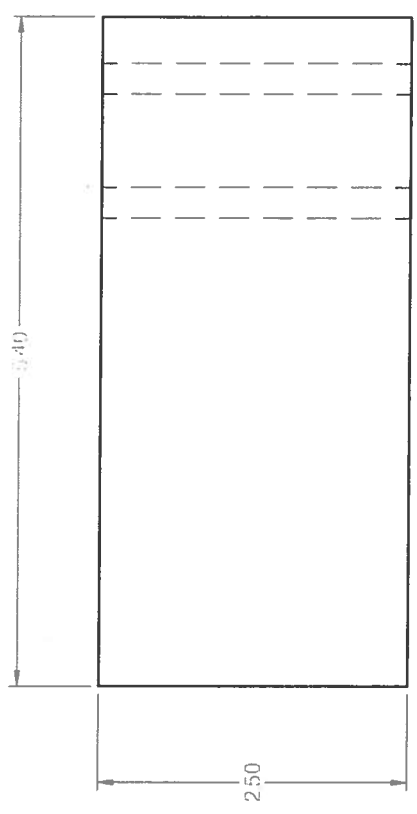

NAME		DATE	
DRAWN	Katrina	03/16/06	
CHECKED			
ENG APPR			
MGR APPR			

UNLESS OTHERWISE SPECIFIED DIMENSIONS ARE IN INCHES ANGLES ±XX" 2 PL ±XXX 3 PL ±XXXX		SIZE	DWG NO	REV
		A3		
		TITLE		
		LEFT STOPPER		
		FILL NAME Left Stopper.dfl		
		SCALE 1:1	WEIGHT	SHEET 1 of 1

SOLID EDGE
UGS - The PLM Company

CAD DRAWINGS: PULLEY SUPPORTS

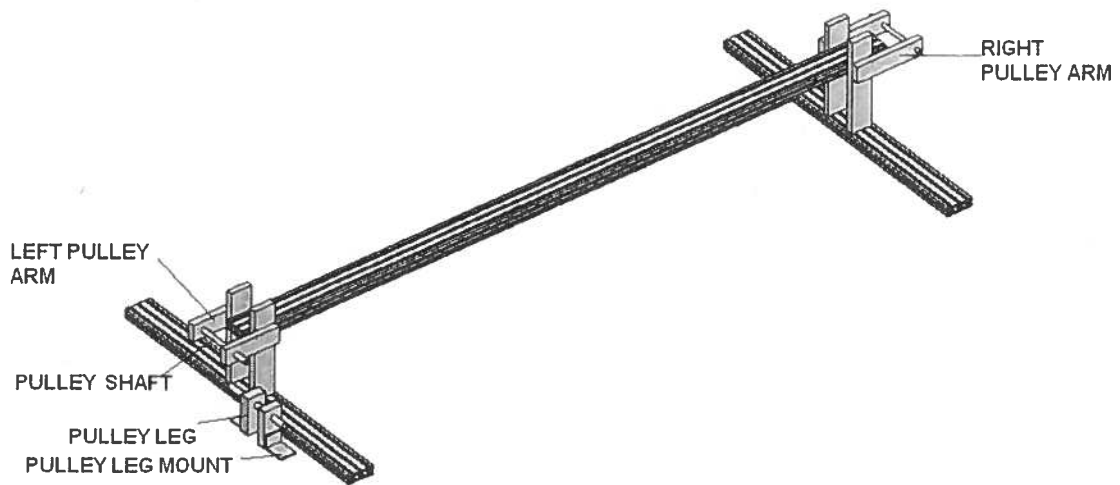

REVISION HISTORY		
REV	DESCRIPTION	DATE
	LEFT PULLEY ARM	

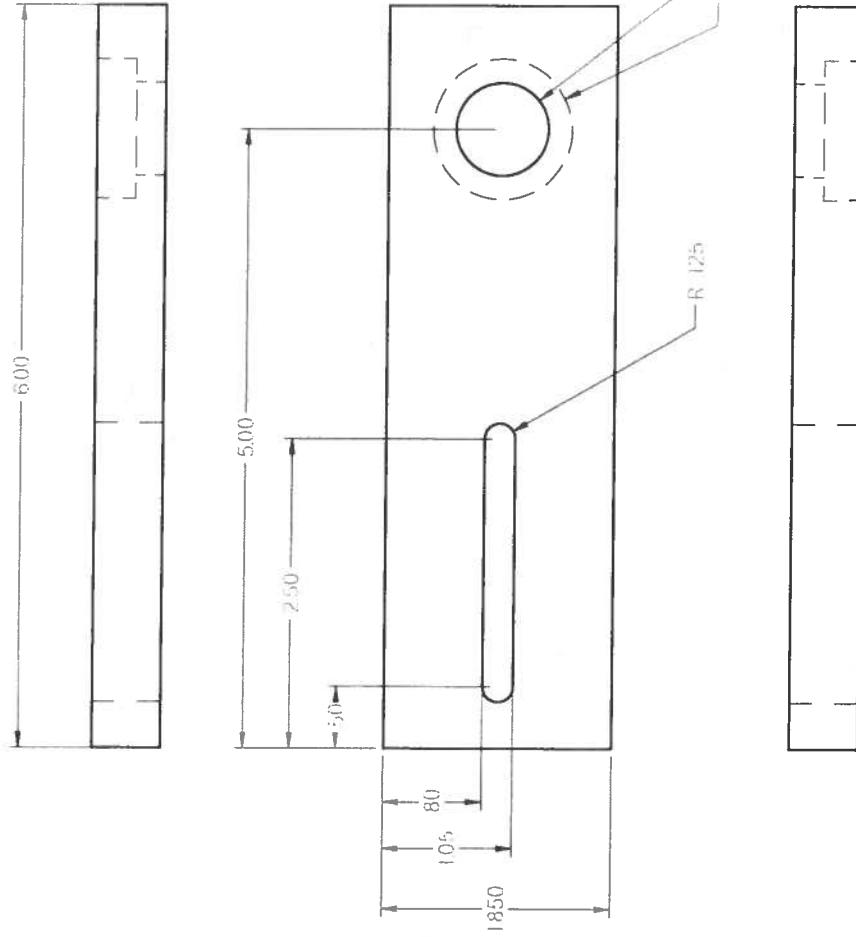
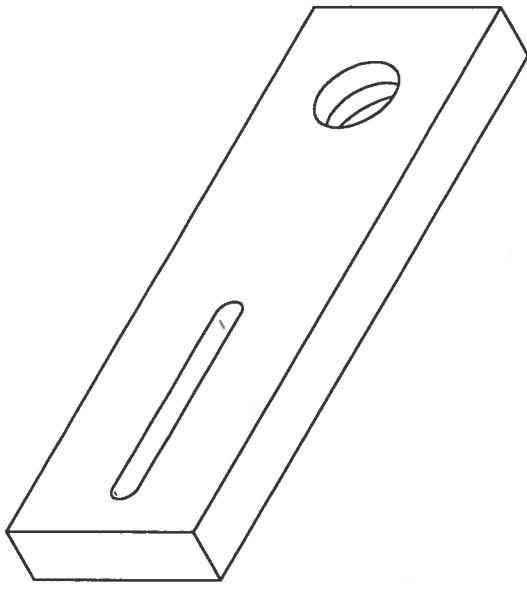

NAME		DATE	
DRAWN	F. J. ...	10-16-06	
CHECKED			
ENG APPR			
MGR APPR			
UNLESS OTHERWISE SPECIFIED DIMENSIONS ARE IN INCHES ANGLES ±XX° 2 PL ±XXX 3 PL ±XXXX			
TITLE		SIZE	DWG NO
LEFT PULLEY ARM		A3	
REV		FILE NAME	REV
		Left Pulley Arm.dwg	
SCALE	1:1	WEIGHT	SHEET 1 OF 1

REVISION HISTORY

REV	DESCRIPTION	DATE	APPROVED
	RIGHT PULLEY ARM		

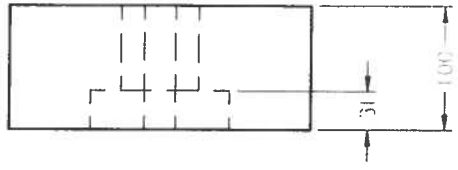
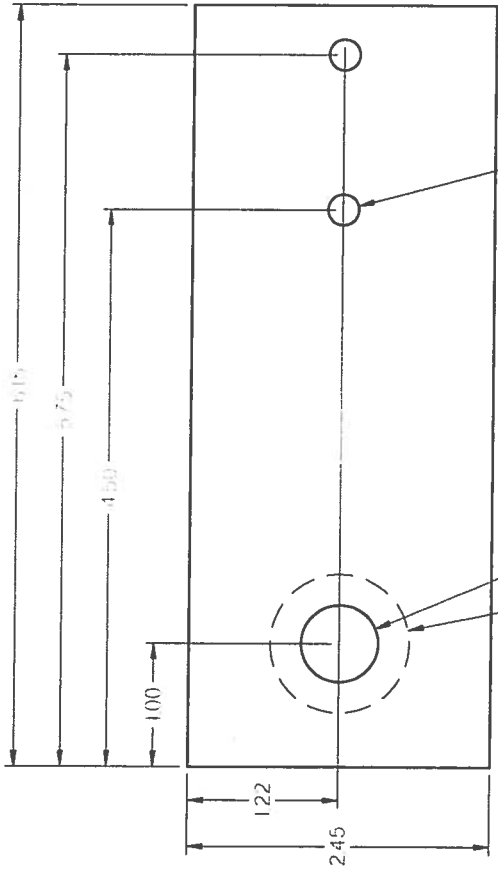
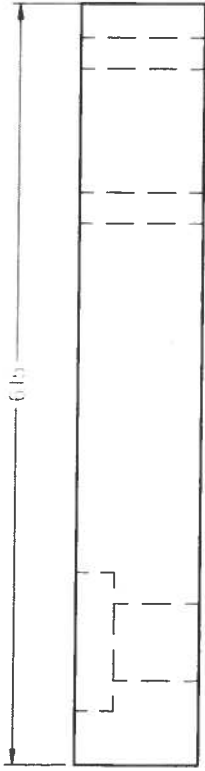
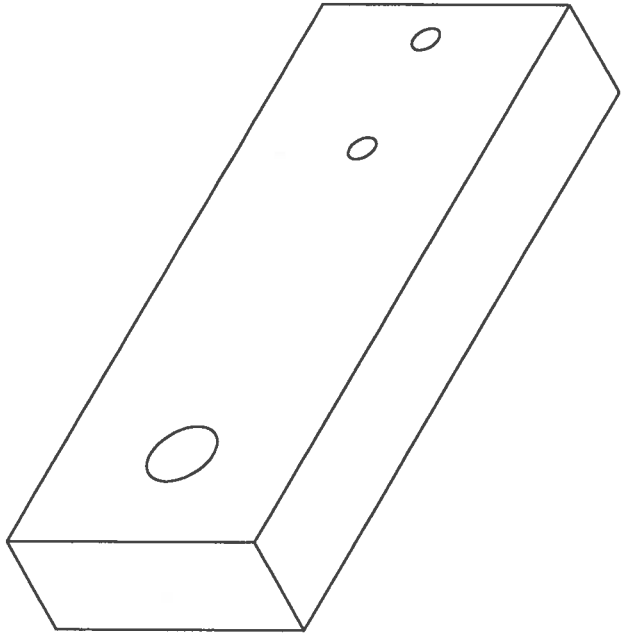

NAME	DATE	SIZE	DWG NO	REV
DRAWN	Kurtmann	A3	03/16/06	
CHECKED				
ENG APPR				
MGR APPR				

UNLESS OTHERWISE SPECIFIED
DIMENSIONS ARE IN INCHES
ANGLES ±XX°
2 PL ±XXX 3 PL ±XXXX

TITLE	SCALE	WEIGHT	SHEET 1 OF 1
RIGHT PULLEY ARM	1:1		

REVISION HISTORY		DATE	APPROVED
REV	DESCRIPTION		
	PULLEY LEG		

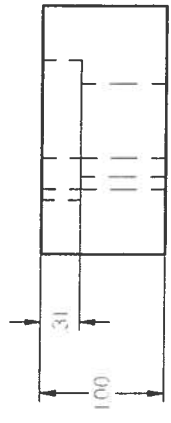
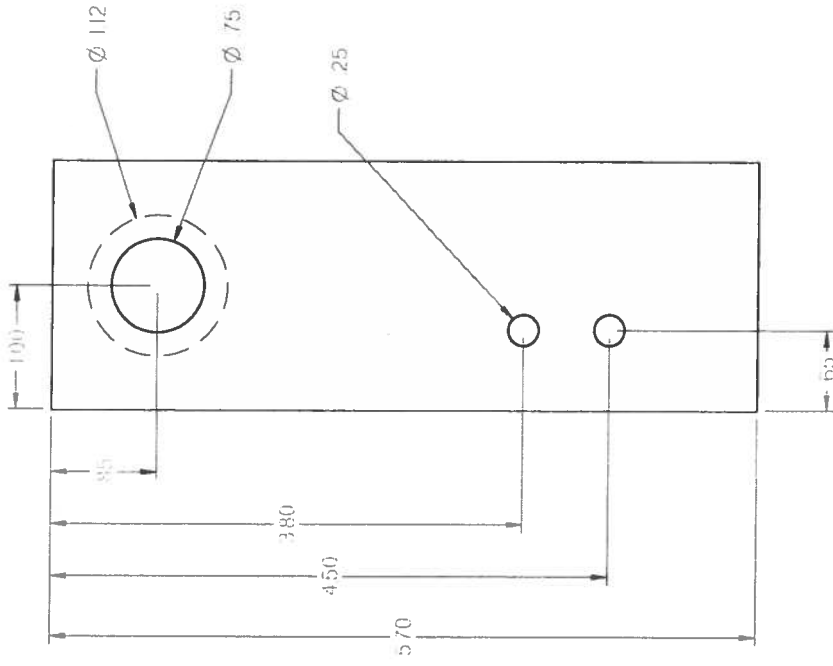
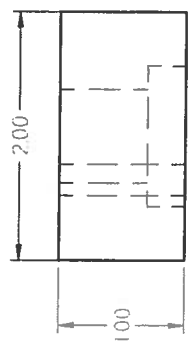
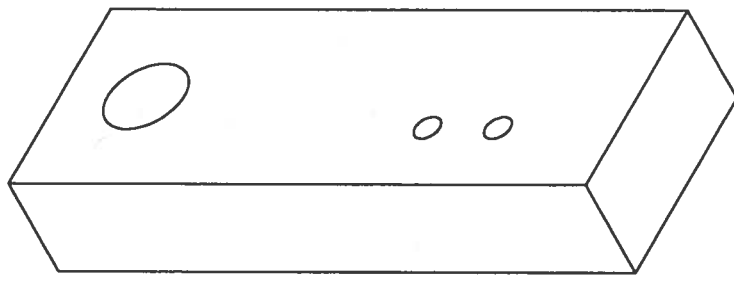

SOLID EDGE		UGS - The PLM Company	
DRAWN		NAME	DATE
CHECKED		Fatima	0-3/16/06
ENG APPR			
MGR APPR			
TITLE		PULLEY LEG	
UNLESS OTHERWISE SPECIFIED DIMENSIONS ARE IN INCHES ANGLES ±XX°		SIZE	DWG NO
2 PL ±XXX 3 PL ±XXXX		A3	
		REV	
		FILE NAME	Pulley Leg.dwg
		SCALE	1:1
		WEIGHT	
		SHEET 1 OF 1	

REVISION HISTORY		
REV	DESCRIPTION	DATE
	PULLEY LEG MOUNTS	
		APPROVED

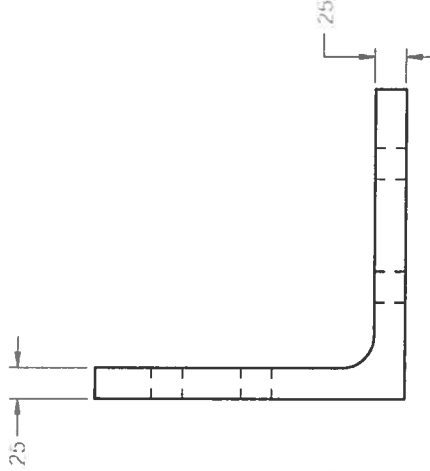
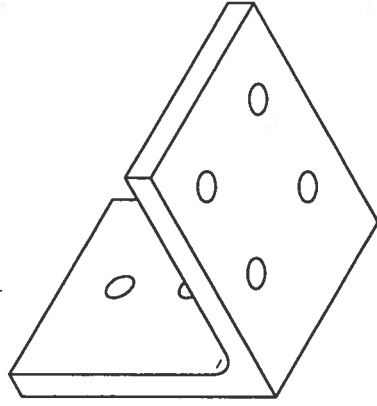
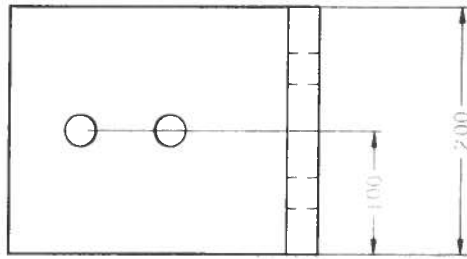
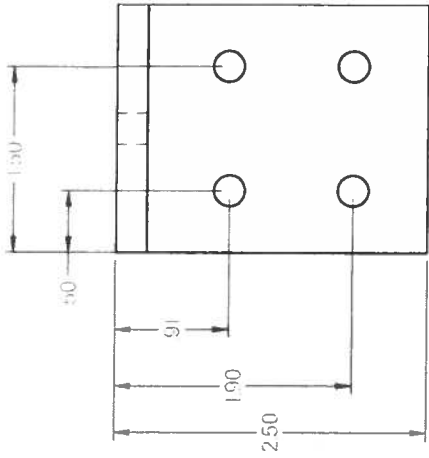

NAME		DATE	
DRAWN	Katrina	03/16/06	
CHECKED			
ENG APPR			
MGR APPR			
UNLESS OTHERWISE SPECIFIED DIMENSIONS ARE IN INCHES ANGLES ±XX° 2 PL ±XXX 3 PL ±X.XXX			
TITLE		SIZE	DWG NO
PULLEY LEG MOUNTS		A3	
FILE NAME: Pulley Leg Mounts.dwg		REV	
SCALE: 1:1	WEIGHT	PROJECT: 11011	

SOLID EDGE
UGS - The PLM Company

REVISION HISTORY		
REV	DESCRIPTION	DATE
	PULLEY SHAFTS	
		APPROVED

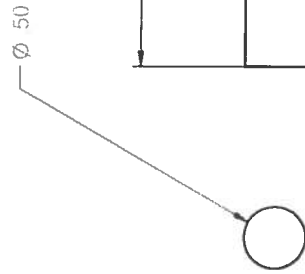
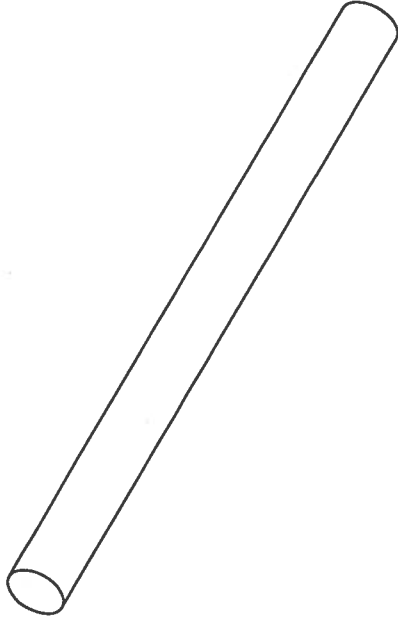

NAME		DATE	
DRAWN	F.OTTEN	03/15/06	
CHECKED			
ENG APPR			
MGR APPR			
UNLESS OTHERWISE SPECIFIED DIMENSIONS ARE IN INCHES ANGLES ±.XX° 2 PL ±.XXX 3 PL ±.XXXX			
SIZE		DWG NO	
A3			
TITLE		REV	
PULLEY SHAFTS			
SCALE 1:1		WEIGHT	
		SHEET 1 OF 1	

SOLID EDGE
UGS - The PLM Company

PULLEY SHAFTS

SIZE DWG NO

A3

UNLESS OTHERWISE SPECIFIED
DIMENSIONS ARE IN INCHES
ANGLES ±.XX°

2 PL ±.XXX 3 PL ±.XXXX

TITLE

SCALE 1:1

WEIGHT

SHEET 1 OF 1

CAD DRAWINGS: TENSION LEGS

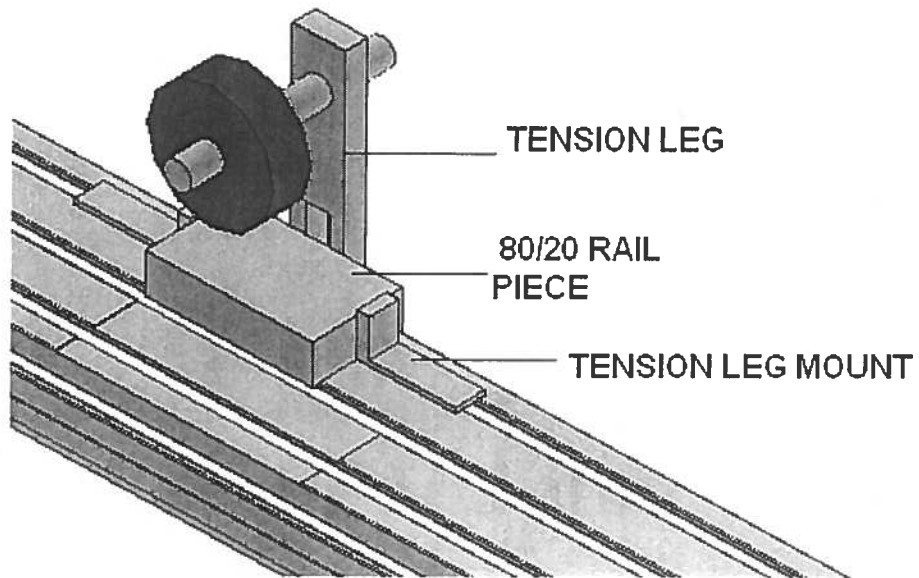

REVISION HISTORY

REV	DESCRIPTION	DATE	APPROVED
	TENSION LEG		

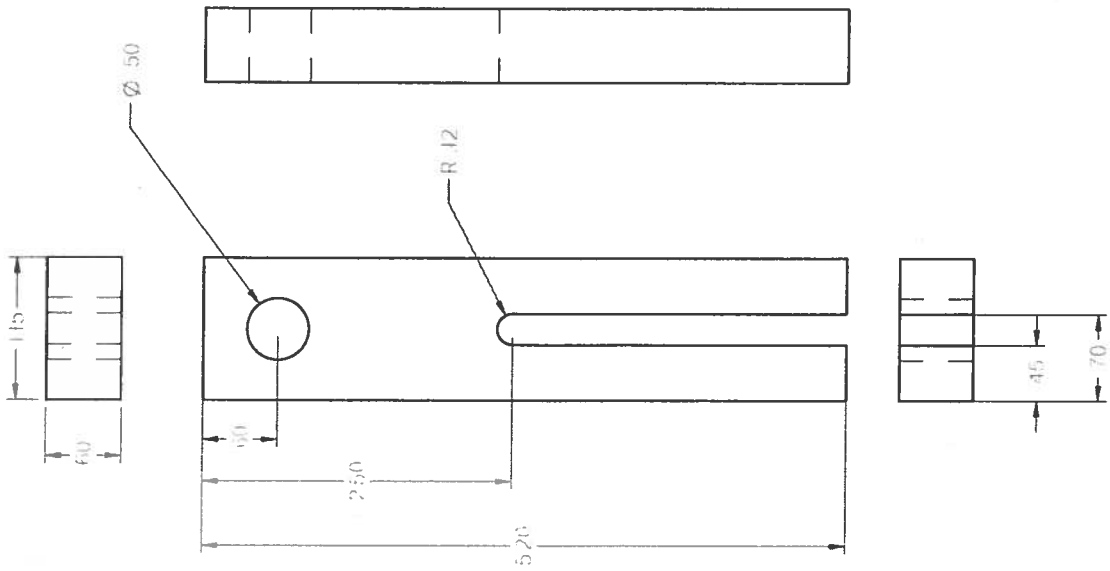
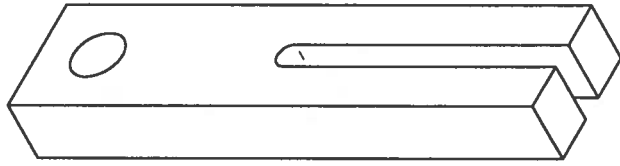

SOLID EDGE		UGS - The PLM Company	
TITLE		TENSION LEG	
SIZE	DWG NO	REV	
A3			
UNLESS OTHERWISE SPECIFIED DIMENSIONS ARE IN INCHES ANGLES ±XX° 2 PL ±X.XX 3 PL ±X.XXX			
SCALE	1:1	WEIGHT	SHEET 1 OF 1

NOTE: ALL HOLES ARE 1/4" THROUGH

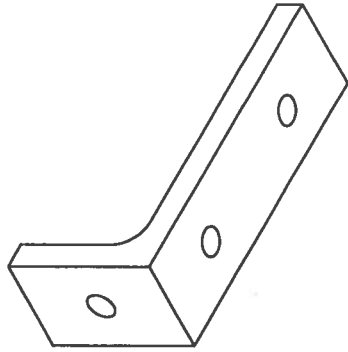
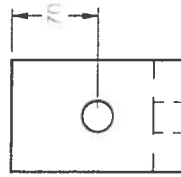
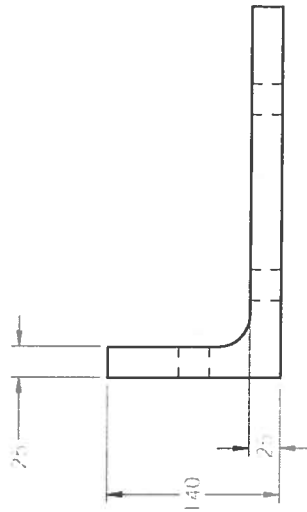
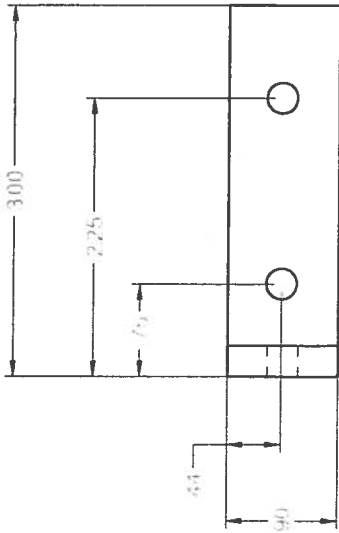

REVISION HISTORY		
REV	DESCRIPTION	DATE
	TENSION LEG MOUNT	

DRAWN		NAME	DATE
		Fotino	07/15/06
CHECKED			
ENG APPR			
MGR APPR			
UNLESS OTHERWISE SPECIFIED DIMENSIONS ARE IN INCHES ANGLES ±XX° 2 PL ±X.XX 3 PL ±X.XXX			
TITLE		TENSION LEG MOUNT	
SIZE	DWG NO	REV	
A3			
FILE NAME		TensionLegMounts.dft	
SCALE	11	WEIGHT	
			SHEET 1 OF 1

SOLID EDGE
UGS - The PLM Company

**CAD DRAWING:
MOTOR MOUNT**

NOTE

- A. 1/4" THROUGH HOLES X 4
- B. 9/32 DIAMETER #4 SCREWS
- C. 0.98" HOLES 0.60" DEEPR X 4

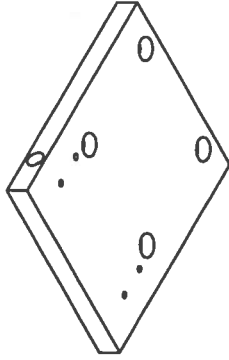
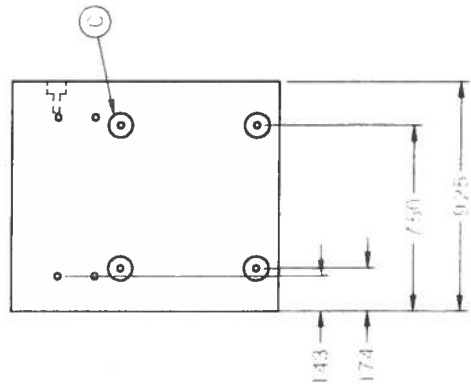
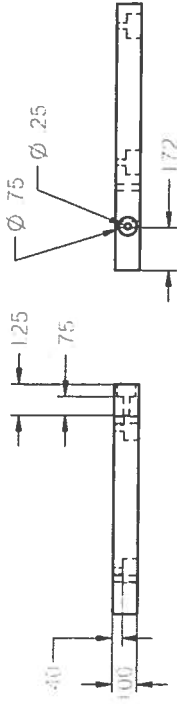
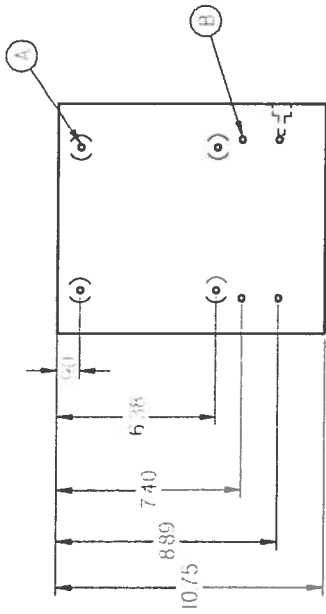

REVISION HISTORY		
REV	DESCRIPTION	DATE
	MOTOR MOUNT	

DRAWN		NAME	DATE
		Kofrmin	04/16/06
CHECKED			
ENG APPR			
MGR APPR			
UNLESS OTHERWISE SPECIFIED DIMENSIONS ARE IN INCHES ANGLES ±XX"			
2 PL ±XXX 3 PL ±XXXX			
SOLID EDGE			
UGS - The PLM Company			
TITLE			
MOTOR MOUNT			
SIZE	DMG NO	REV	
A3			
FILE NAME		WEIGHT	
Motor Mount.dwg			

CAD DRAWINGS: PULLEYS

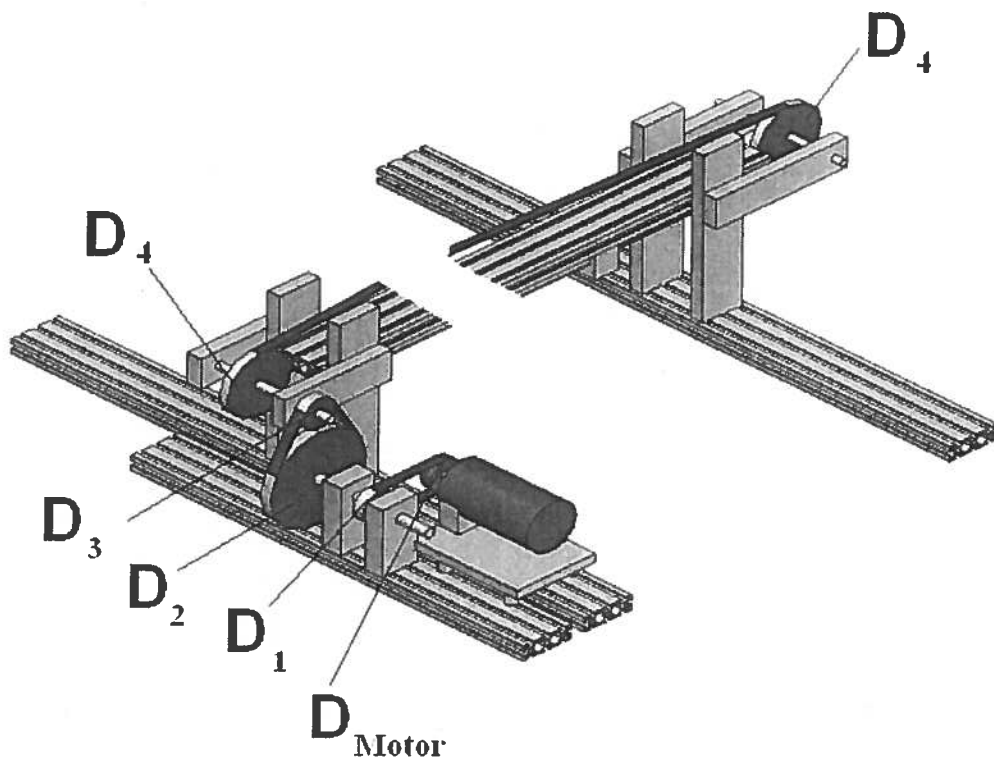

To derive the correct speed of the carriage, various sized pulleys were used. The following pulley diameters were used.

D_{motor}	2.865 in
D_1	4.297 in
D_2	6.000 in
D_3	1.000 in
D_4	4.297 in

D_{motor} , D_1 , and D_4 were all $3/8$ " pitch pulleys, $1/2$ " wide. D_2 and D_3 were both v-belt pulleys.

NOTE

- A. 3/8" PITCH
- B. 1/4 - 28 SET SCREW

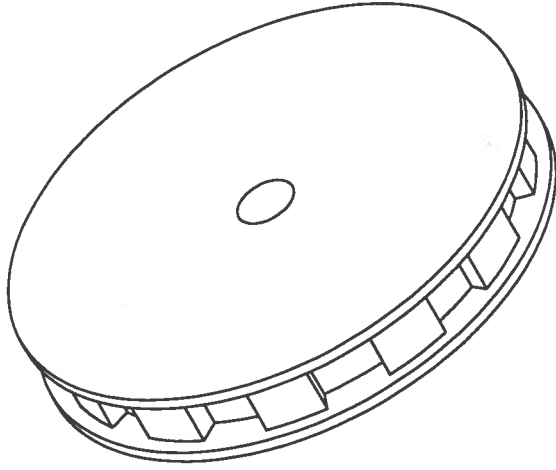
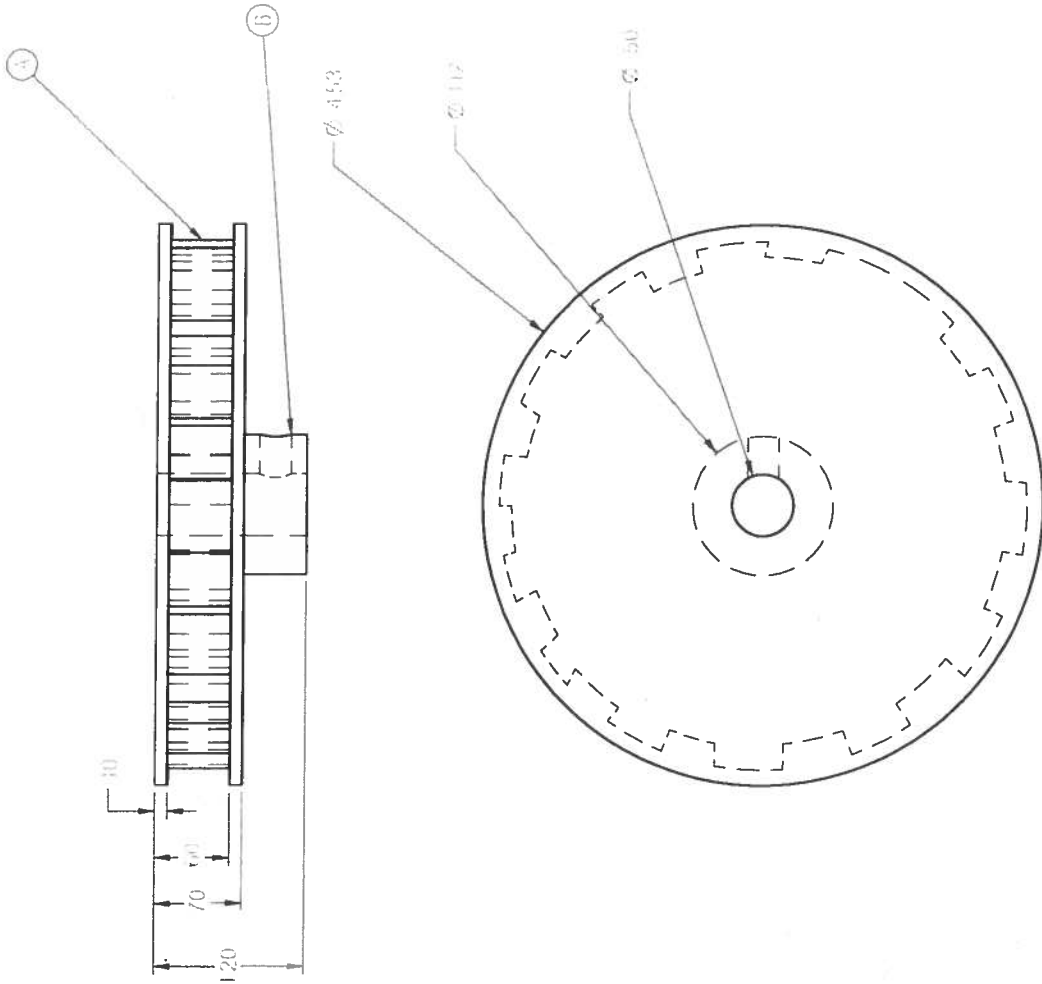

REVISION HISTORY		
REV	DESCRIPTION	DATE
	TIMING PULLEY	
		APPROVED

DRAWN		NAME	DATE
CHECKED		F. Orma	03/16/06
ENG APPR			
MGR APPR			
UNLESS OTHERWISE SPECIFIED DIMENSIONS ARE IN INCHES ANGLES ±XX°			
2 PL ±XXX 3 PL ±XXXX			
TITLE		TIMING PULLEY	
SIZE	DWG NO	REV	
A3			
FILE NAME: P:\p\p...			
SCALE	1:1	WEIGHT	SHEET 1 OF 1

SOLID EDGE
UGS - The PLM Company

Bill of Materials

Team Water Table's Bill of Materials:

Section	Description	Quantity	Manufacturer	Part Number	Price (\$)	
Carriage:	Ball Bearing, ID=0.25", OD=0.625"	1	KYK	R4	0.00	
	Wheel Plate Assembly	1	BWC	W2SS x Wheels	133.39	
	Screw, Knurled Head	1	Grainger	2L581	6.79	
	Carriage Plate 1	1	S. Fabricated	Machine Shop	0.00	
	Carriage Plate 2	1	S. Fabricated	Machine Shop	0.00	
	Clamp	1	S. Fabricated	Machine Shop	0.00	
	Hexagonal Screw, 1/4" - 20	6	MHH	Unknown	0.00	
	Flat Head Screw, 1/8"	1	Unknown	Unknown	0.00	
	Motor:	Gearmotor, 40RPM, 12VDC, 75lbinf	1	Dayton	1L471	201.94
		Gearbelt, L, 60 Teeth	1	Grainger	2L581	9.43
Isolator, Vibration		5	Grainger	3CC02	8.85	
L-Bracket, 3 - 0.25" Holes		1	S. Fabricated	Machine Shop	0.00	
L-Bracket Screws, 1/4" - 20		2	MHH	Unknown	0.00	
Isolator, Vibration Screws		4	ACE Hardware	Unknown	3.50	
Allen Wrench Screw, 1/4" - 20		2	ACE Hardware	Unknown	0.75	
Pulley System:		Slip Belt	1	FHP	2L240	5.95
		Open Ended Timing Belt, 5 Meters	1	Kaman	740120	60.15
		Timing Pulley, 3/8P, ID=0.5", OD=6"	1	Stock Drive Products	A 6A 4-24DF050516	31.90
	Timing Pulley, 3/8P, ID=0.5", OD=4.5"	3	Stock Drive Products	A 6Z 4-36DF03016	51.84	
	Ball Bearing, ID=0.5", OD=1.125"	8	KYK	R8	0.00	
	Gearbelt Pulley, OD=2.5", ID=1.125"	2	Browning	18LG050	31.14	
	Post, 2" x 5.75" x 1"	2	S. Fabricated	Machine Shop	0.00	
	Post, 2" x 12" x 1"	4	S. Fabricated	Machine Shop	0.00	
	Shaft, OD=0.5", L=6.5"	1	S. Fabricated	Machine Shop	0.00	
	Shaft, OD=0.5", L=9"	2	S. Fabricated	Machine Shop	0.00	
	T-Bar, L=1.25"	2	S. Fabricated	Machine Shop	0.00	
	Tensioner Screws, 1/4" - 20	14	MHH	Unknown	0.00	
	Right Side Components:	Right Arm, 2" x 6.5" x 0.5"	2	S. Fabricated	Machine Shop	0.00
		Right Arm Attachment Screws, 1/4" - 20	4	MHH	Unknown	0.00
Right Arm Mounting Screws, 1/4" - 20		16	MHH	Unknown	0.00	

	Right Side Stopper	1	S. Fabricated	Machine Shop	0.00
Left Side Components:	Right Side Stopper Screws, 1/4" - 20	4	MHH	Unkown	0.00
	Left Arm, 1.5" x 6" x 0.5"	2	S. Fabricated	Machine Shop	0.00
	Left Arm Attachment Screws, 1/4" - 20	4	MHH	Unkown	0.00
	Left Arm Mounting Screws, 1/4" - 20	16	MHH	Unkown	0.00
	Left Side Stopper	1	S. Fabricated	Machine Shop	0.00
	Left Side Stopper Screws, 1/4" - 20	4	MHH	Unkown	0.00
Railing System:	Track Plate Assembly	1	BWC	2190 mm-ss	324.28
	T-Bar, L=6.583'	1	8020	1030	0.00
Table Mount:	T-Bar, L=3.125'	2	8020	1030	0.00
	T-Bar, L=2.583'	1	8020	1030	0.00
	L-Bracket, 12 - 0.25" Holes	4	ACE Hardware	Unkown	1.00
	L-Bracket, 6 - 0.25" Holes	3	S. Fabricated	Machine Shop	0.00
	L-Bracket, 4 - 0.25" Holes	1	S. Fabricated	Machine Shop	0.00
	L-Bracket, 3 - 0.25" Holes	1	S. Fabricated	Machine Shop	0.00
	L-Bracket Screws, 1/4" - 20	18	MHH	Unkown	0.00
	Control Systems Parts: Including limit switches, etc.	7	HSC Electronics		19.45
Control Systems:	Simple Bridge Controller	1	Solutions Cubed	SB_1	25.00
	Limit Switch Screws, 1/8"	4	Unkown	Unkown	0.00

Total Cost (\$): 915.36