

# REFLECTANCE/TRANSMITTANCE SPHERES

Accurate and Flexible, Designed for Reflectance and Transmittance Measurements

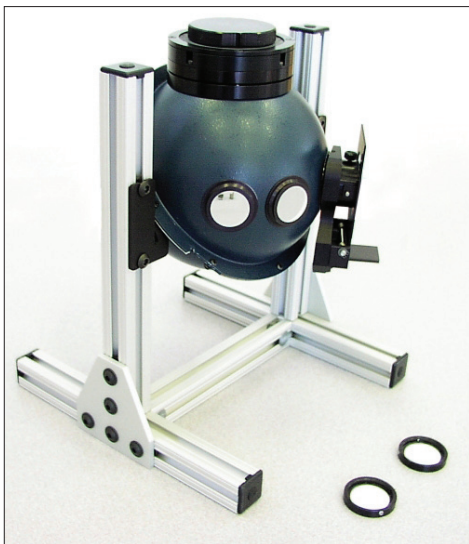

## MEASURE:

- Reflectance and Transmittance of Materials
- Reflectance of Opaque Samples
- Transmittance of Turbid Samples
- Color Properties
- Reflectance System Design
- Infrared Reflectance
- Reflectance vs. Angle

## ACCURATE

Labsphere's Reflectance/Transmittance Sphere Assemblies constitute one of the most basic reflectance measurement products and can be used to measure the reflectance or transmittance of a wide variety of sample mediums. Offered in two standard designs, each sphere is available in one of two reflective coatings; Spectrafect®, our highly diffuse reflective coating effective over the 300 - 2400 nm range and Infragold®, designed for use in the 0.7 - 20  $\mu\text{m}$  wavelength range.

The RT Spheres feature five 1 inch diameter ports to accommodate sample and reference beams necessary for a  $8^\circ$  double beam geometry, as well as port plugs required for  $8^\circ$  single beam geometry. A 0.5 inch detector port is located at the top of the sphere. A specular light trap is included for specular subtraction methods.

RTC Spheres add further versatility with a center-mounted sample holder so users are able to measure reflectance and transmittance versus incident angle of radiation. Five ports accommodate sample and reference beams with a center-mount stage located at the top of the sphere, and a 0.5 inch detector port located at the bottom of the sphere assembly.

Both sphere assemblies are suitable for all geometric transmittance measurements. The RT Sphere Assembly can perform reflectance measurements in the specular included ( $8^\circ/h$ ) and specular excluded ( $8^\circ/d$ ) geometries. The RTC Integrating Spheres provide specular included ( $8^\circ/h$ ) and specular excluded ( $8^\circ/d$ ) geometries, as well as reflectance measurement capabilities at variable angles of incidence.

The sphere ports are knife-edged to permit collection of wide-angle scatter and the baffling is minimized to allow the detector a maximum view of the sphere wall. A detector port is located at the top or bottom of the sphere and baffled from receiving direct radiation from the sample and reference ports.

## SPECTRAFLECT® REFLECTANCE COATING

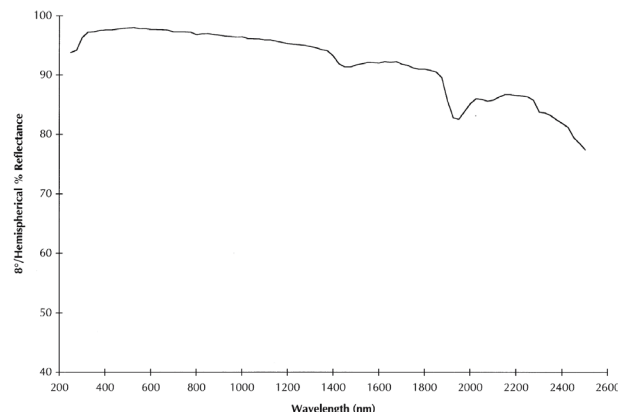

## INFRAGOLD® REFLECTANCE COATING

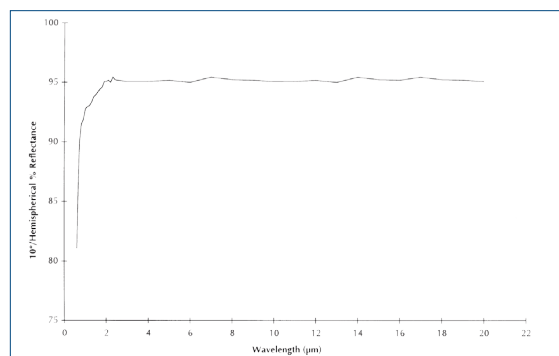

# Specifications and Ordering Information

Model Number	RT-060-SF	RT-060-IG	RTC-060-SF	RTC-060-IG
Order Number:	AS-02484-100	AS-02485-100	AS-02484-000	AS-02485-000
Sphere Diameter:	6 inches	6 inches	6 inches	6 inches
Sphere Coating:	Spectrafect®	Infragold®	Spectrafect®	Infragold®
Optimum Spectral Range:	250 - 2500 nm	0.7 μm - 20 μm	250 - 2500 nm	0.7 μm - 20 μm
Detector Port Diameter:	0.5 inch	0.5 inch	0.5 inch	0.5 inch
Sample and Reference Ports:	Five	Five	Five	Five
Sample and Reference Port Diameters: (Qty)	1 inch (5)	1 inch (5)	1 inch (3) 1.25 inch (2)	1 inch (3) 1.25 inch (2)
Sphere Mount:	1/4 - 20 boss mounting post and base assembly	1/4 - 20 boss mounting post and base assembly	Adjustable H - frame assembly	Adjustable H - frame assembly

## RT-060-SF AND RT-060-IG REFLECTANCE/TRANSMITTANCE SPHERES

Labsphere's RT-060-XX Sphere features five 1 inch diameter ports to accommodate sample and reference beams necessary for a 8° double beam geometry, as well as port plugs required for 8° single beam geometry. Two one inch sample holders are provided with the sphere to mount the sample and a reflectance/transmittance standard. A 0.50 inch detector port is located at the top of the sphere. The sphere also comes with a detector mask to limit the detector field of view. A specular light trap is included for specular subtraction methods.

The spheres are appropriate for specular included and specular excluded reflectance measurements, measurements of forward scattering and back scattering, and measurement of the transmittance of turbid or scattering samples. The sphere ports are knife-edged to permit collection of wide angle scatter and the baffling is minimized to allow the efficient integration. To ensure high sphere efficiency, the total port area is <5% of the sphere surface area. The integrating spheres each have a mounting assembly consisting of a rod base with a 1/4 - 20 boss, so sphere height is easily adjustable.

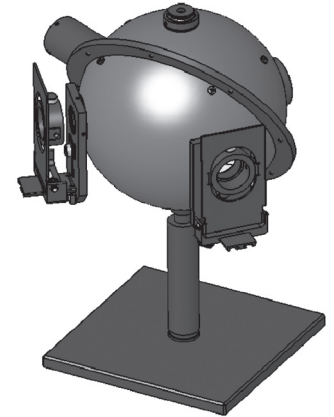

## RTC-060-SF AND RTC-060-IG REFLECTANCE/TRANSMITTANCE SPHERES WITH CENTER MOUNT

With the addition of center-mounted sample holders, users of Labsphere's RTC-060-XX are able to measure reflectance, and in some cases, transmittance versus incident angle of radiation.

The RTC-060-IG Sphere features four ports to accommodate sample and reference beams. Three ports are 1 inch diameter and two ports are 1.25 inch diameter. A center-mount stage is located at the top of the sphere and a 0.5 inch detector port is located at the bottom of the sphere assembly. The sphere comes with a detector mask to limit the detector field of view.

The RTC Series Integrating Sphere Assemblies include five sample holders: one center-mount sample holder, two 1.25 inch diameter sample holders and a single one inch device for further flexibility. The center mount sample holder allows for the measurement of reflectance versus incident angle of a wide variety of samples. The jaw-style center mount sample holder is included with the sphere, while clip and cuvette-style center mount sample holders are optional accessories. The jaw-style may be used for samples that can be clamped. Samples as large as 1 inch by 2 inches and up to 0.38 inches thick can be held by the jaws of the sample holder. The clip style center-mount sample holder is designed for thin films or samples which do not have the rigidity to be held by the jaws-style sample holder. Samples up to 1.50" x 2" x 0.125" thick can be held using the clip-style center-mount sample holder. The cuvette-style holder holds standard 12.5 mm square cuvettes and is used to hold liquids and powders for absorbance and scatter characterization.

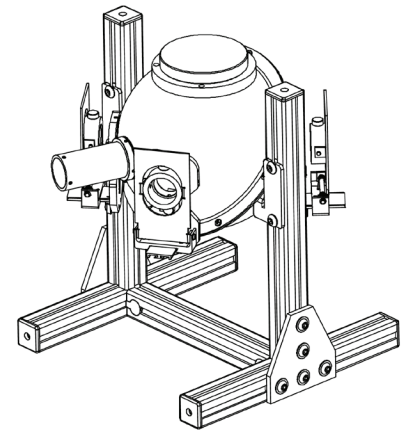

## Optional Accessories

Koehler Illuminator Assembly, KI-120	AS-02509-100
Reflectance Standard Set	Choose your own
Radiometer/Photometer System Control, SC 6000	AS-02702-000
Labsphere Detector Assemblies	Choose your own
Clip-Style Center-Mount Sample Holder, CMSH-RTC-CLIP-SF	AS-02759-000
Cuvette-Style Center-Mount Sample Holder, CMSH-RTC-CUV-SF	AS-02728-000
Port Adaptor for OOI 74 Series Columnator Lenses, PA-100-74S	AS-02763-000